

Spalding Manuscript Writing

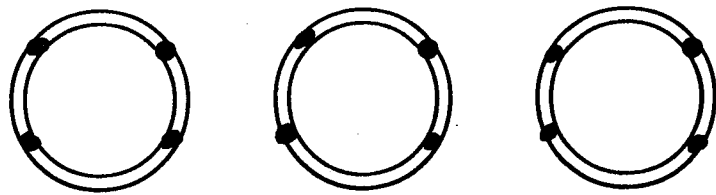

Spalding Lower-Case Letters

Spalding Lower-case Manuscript Letters

Rules: All letters sit on a base line. Letters are either tall or short.
a is a short letter. Begin at 2. Go up and around the clock to 2 and, without lifting the pencil, pull a line straight down to the base line.

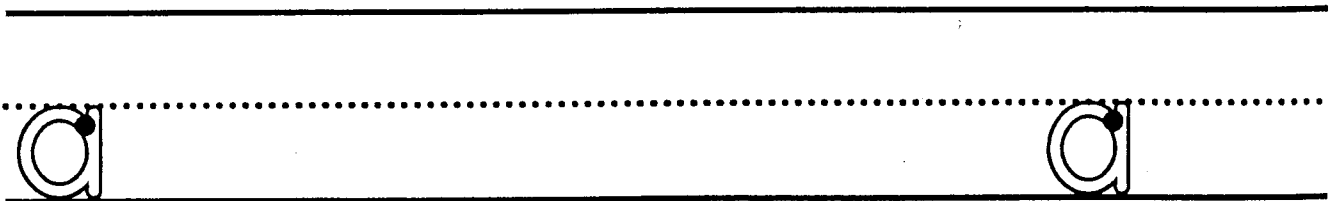
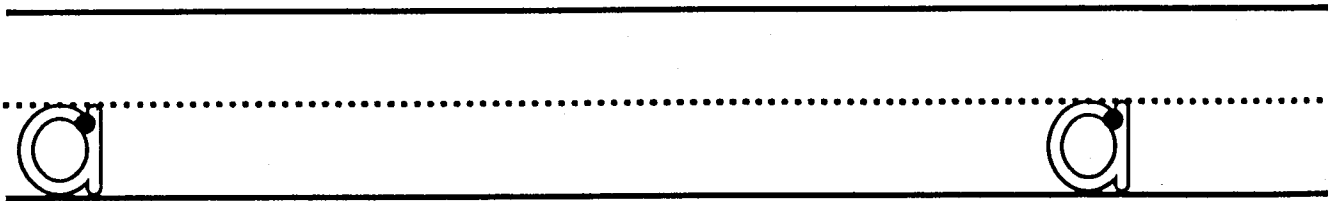
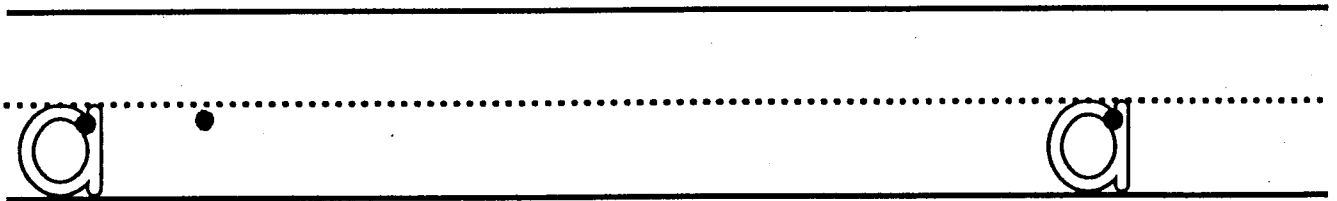
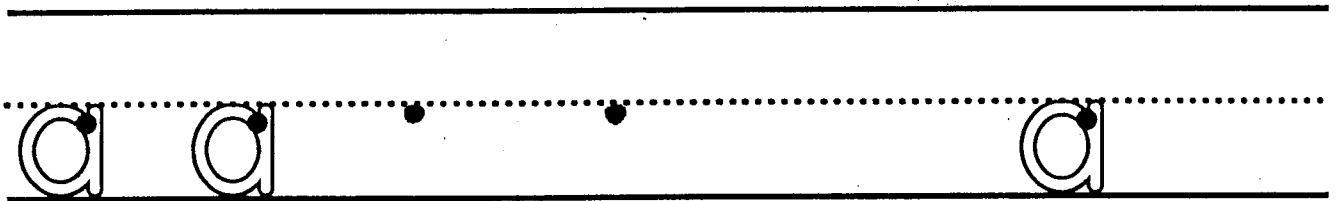
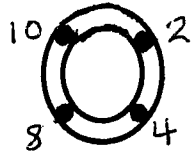

a is a short letter. Begin at 2, go up and around the clock to 2 and, without lifting the pencil, pull a line straight down to the base line.

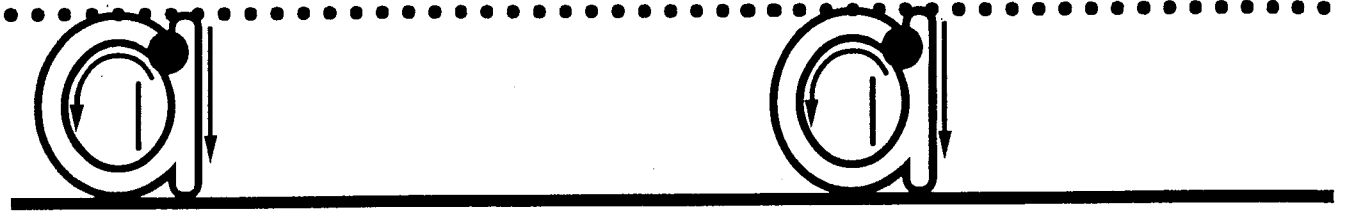

a . . . a

a . . . a

c _ n m _ n c _ t

m _ t f _ n r _ t

Spalding Lower-case Manuscript Letters

Rules: All letters sit on a base line. Letters are either tall or short.

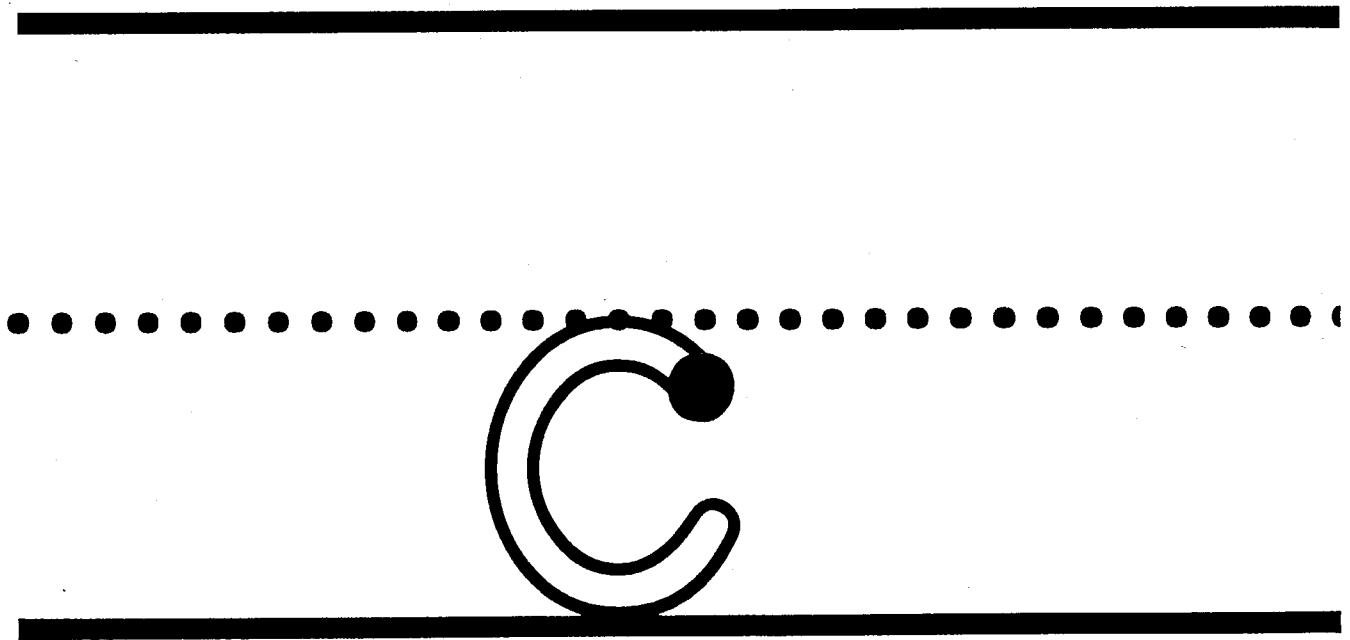
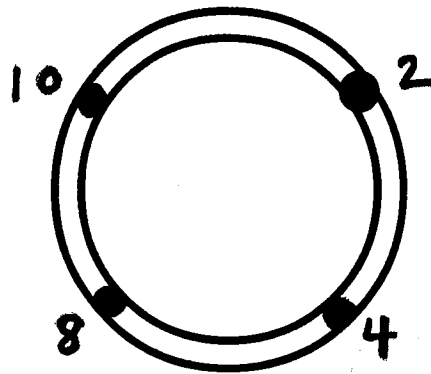

This is a short letter. Begin at 2, go up and around the clock and stop at 4.

Spalding Lower-case Manuscript Letters

Rules: All letters sit on a base line. Letters are either tall or short.

This is a short letter. Begin at 2, go up and around the clock and stop at 4.

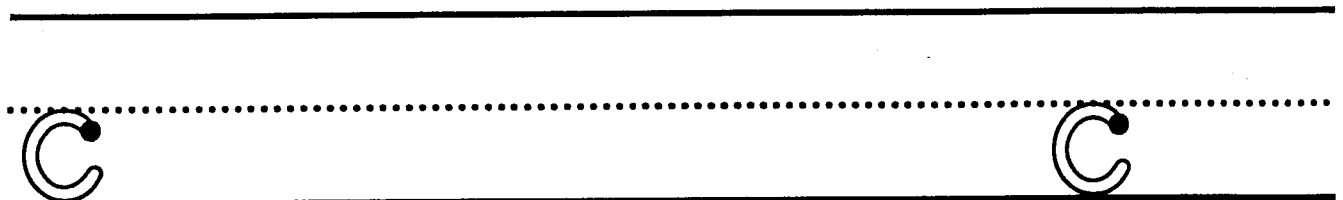
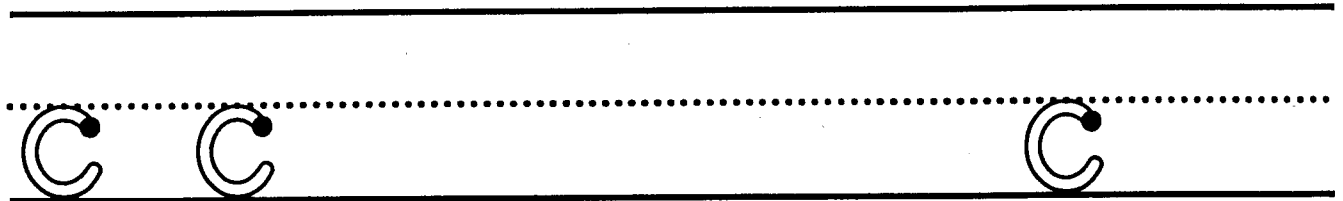
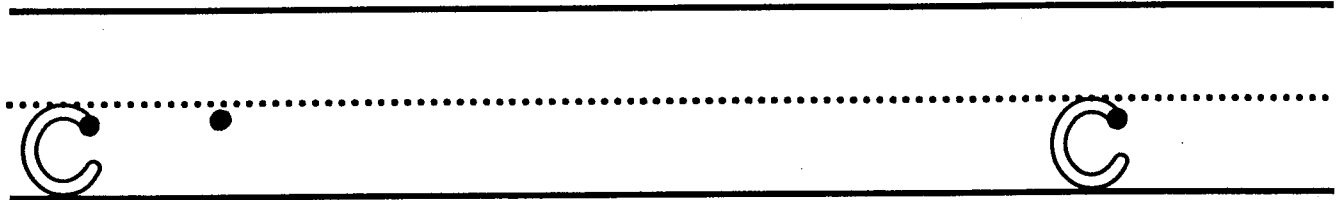
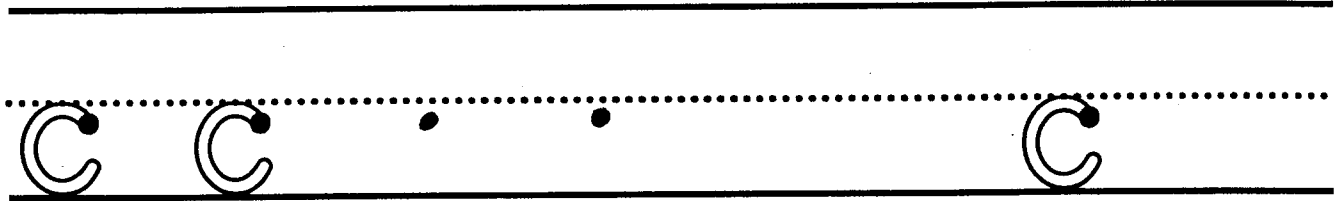
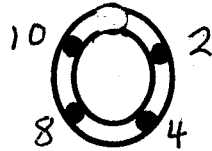

c is a short letter. Begin at 2, go up and around the clock to 2 and stop at 4.

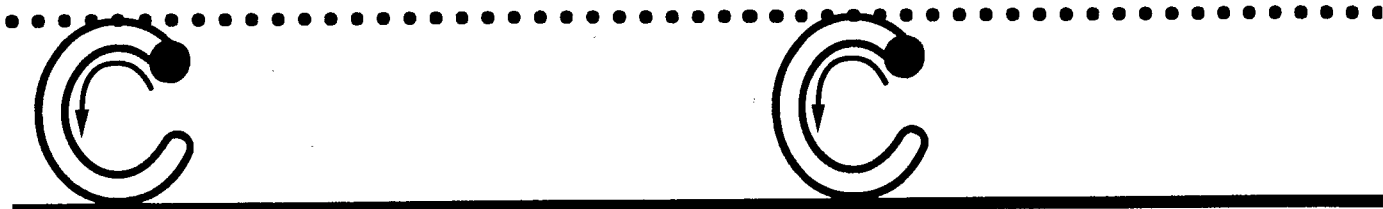

c

c

c

c

can

ack

cat

can

ack

cat

Spalding Lower-case Manuscript Letters

Rules: All letters sit on a base line. Letters are either tall or short.

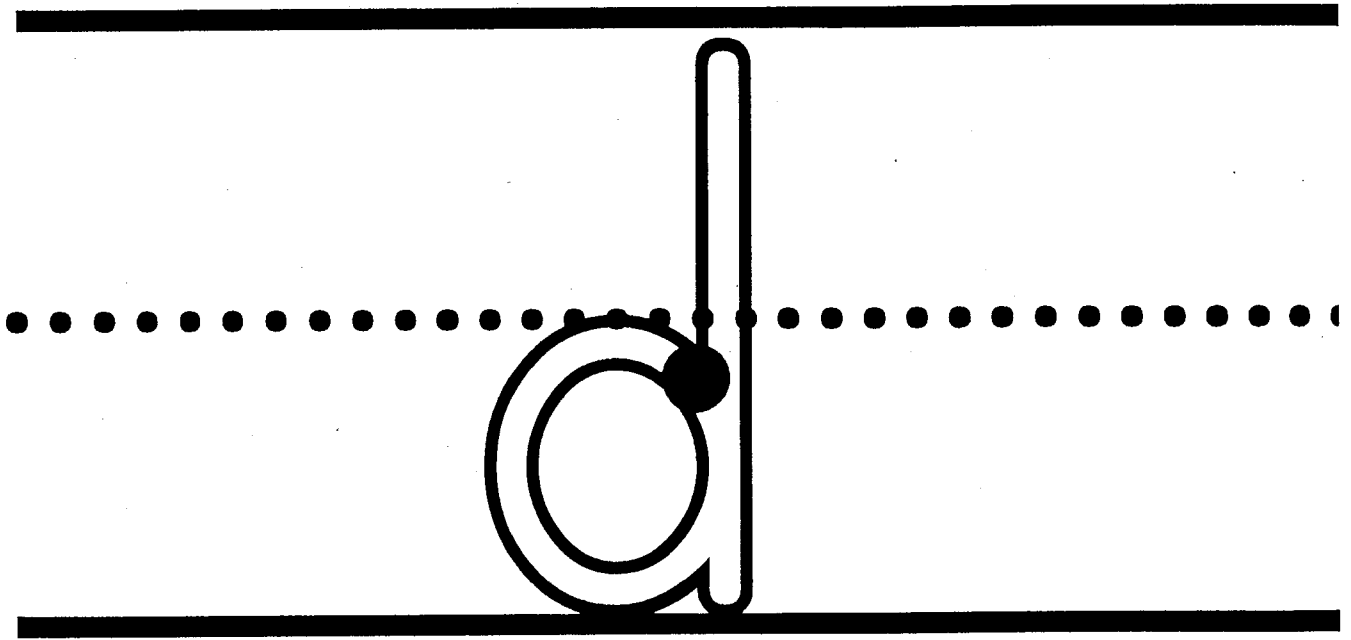
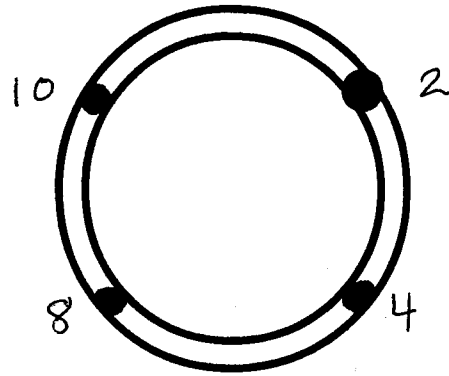

This is a short letter with a tall part. Start at 2 to make the short part, go up and around the clock to 2. go straight up to the line above and pull a line straight down to the base line.

Spalding Lower-case Manuscript Letters

Rules: All letters sit on a base line. Letters are either tall or short.

This is a short letter with a tall part. Start at 2 to make the short part, go up and around the clock to 2. Go straight up to the line above and pull a line straight down to the base line.

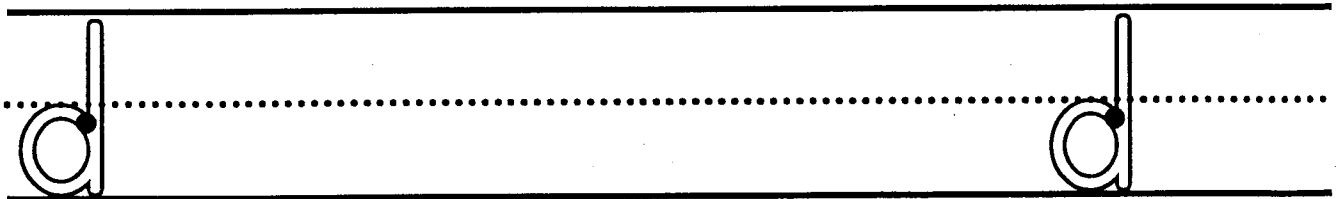
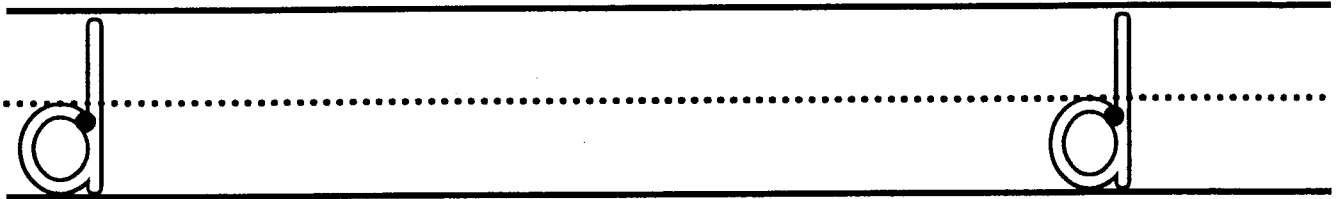
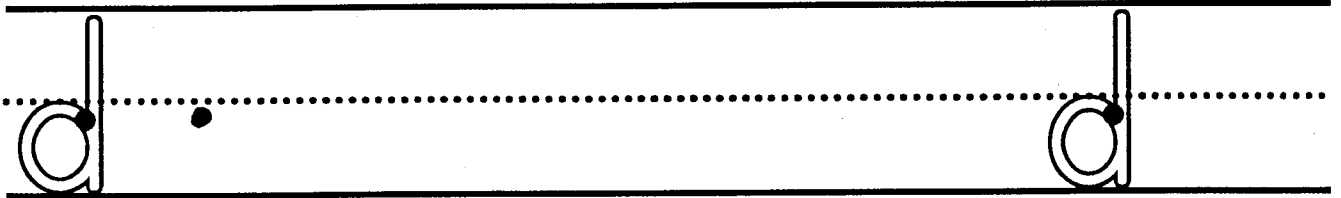
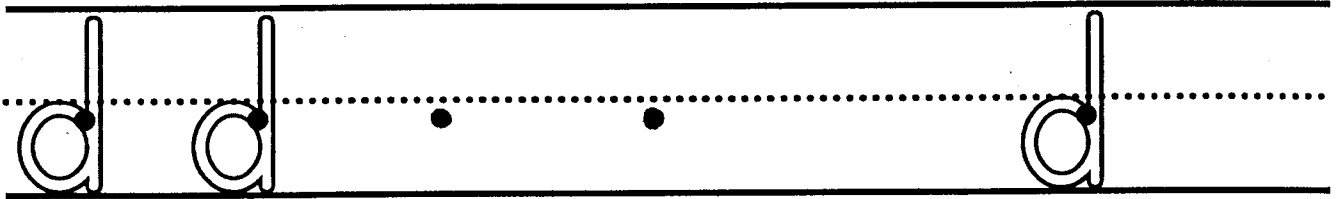
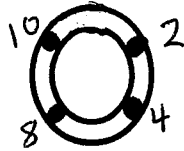

This is a short letter with a tall part. Start at 2 to make the short part. Go up and around the clock to 2. Go straight up to the line above and pull a line straight down to the base line.

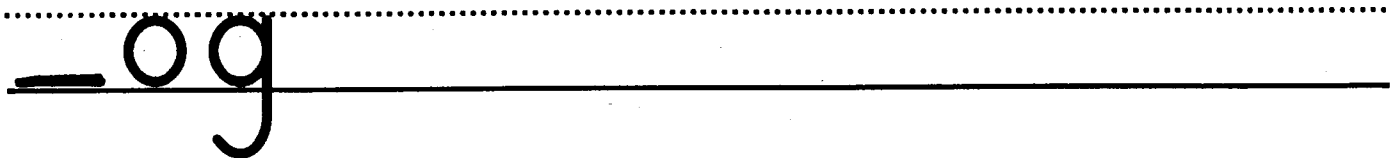
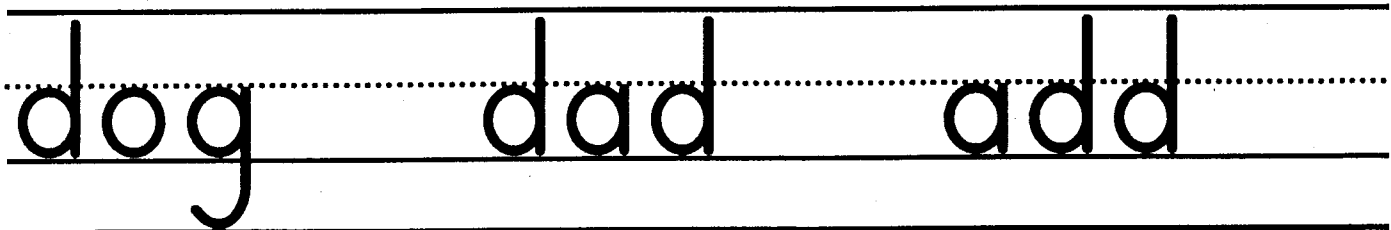
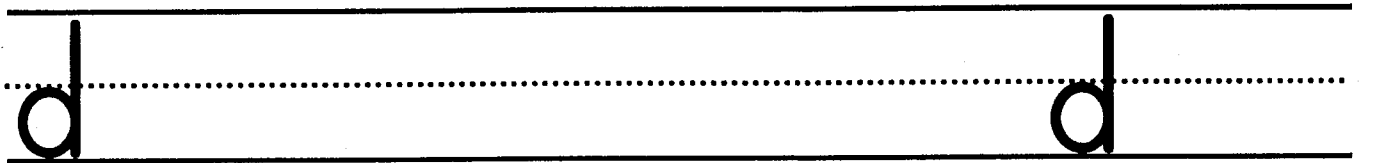
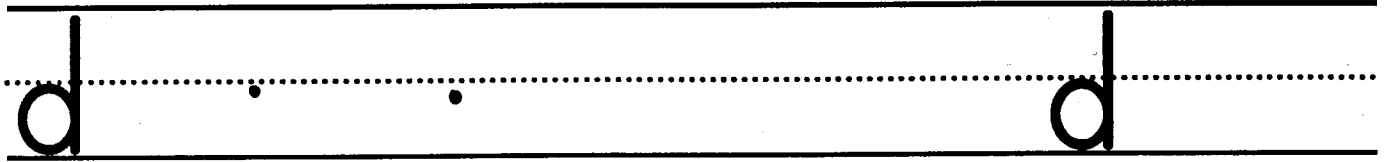
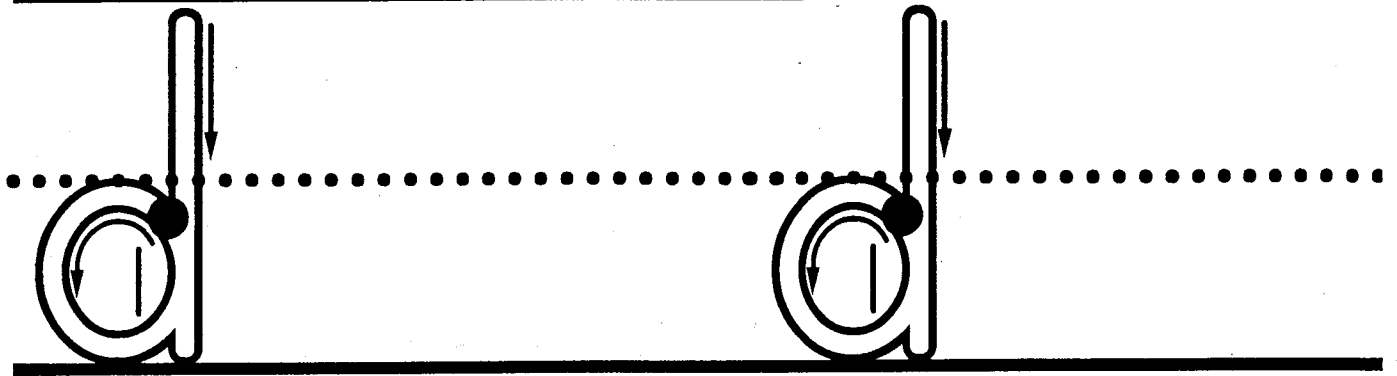

Spalding Lower-case Manuscript Letters

Rules: All letters sit on a base line. Letters are either tall or short.

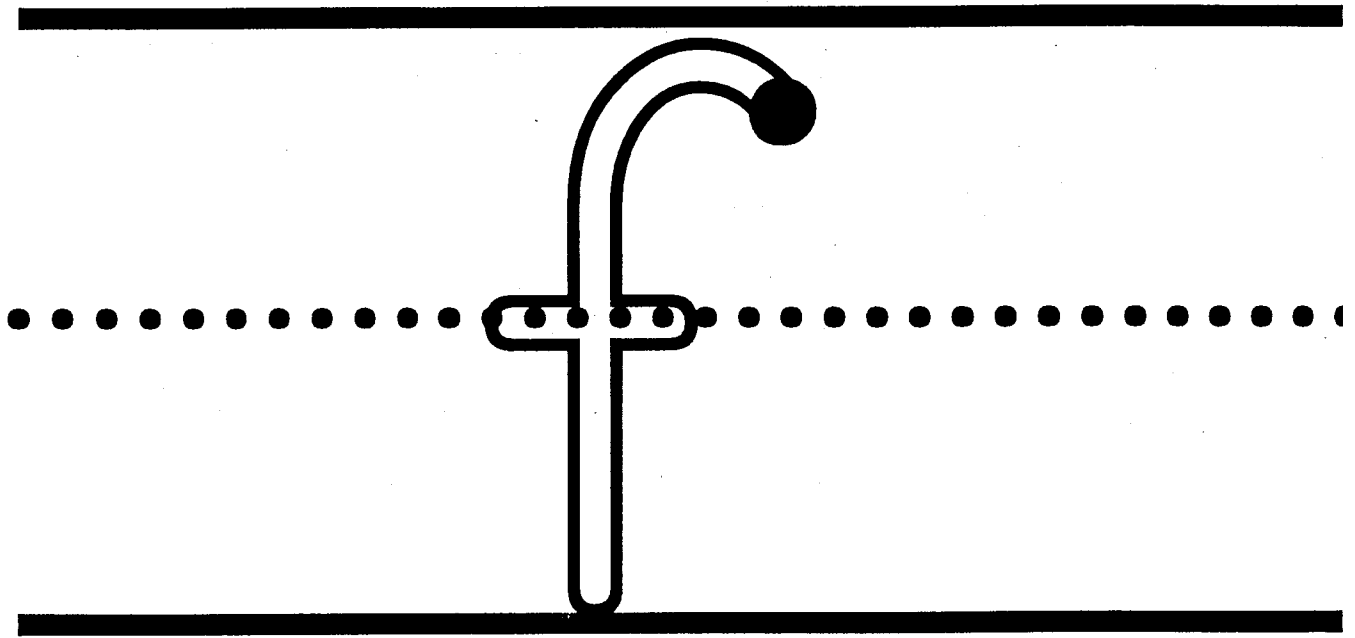
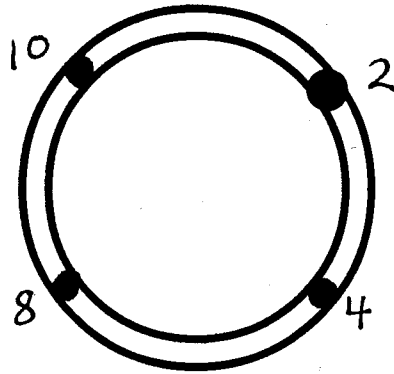

f is a tall letter. It starts below the line above. at 2. Go up around the top to 10. pull straight down to the base line. Lift the pencil to put a tiny cross in the direction in which we write.

Spalding Lower-case Manuscript Letters

Rules: All letters sit on a base line. Letters are either tall or short.

f is a tall letter. It starts below the line above, at 2. Go up around the top to 10, pull straight down to the base line. Lift the pencil to put a tiny cross in the direction in which we write.

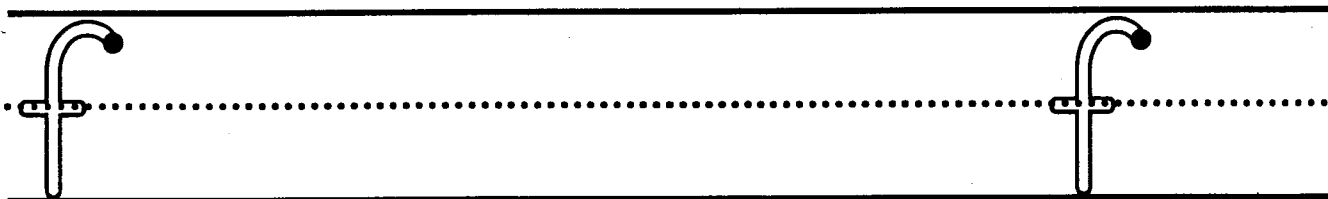
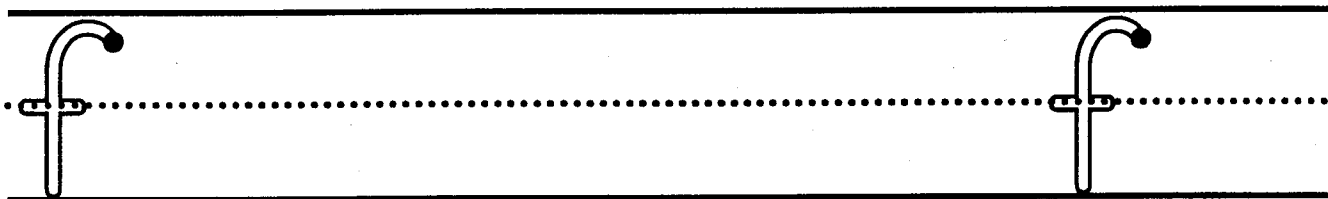
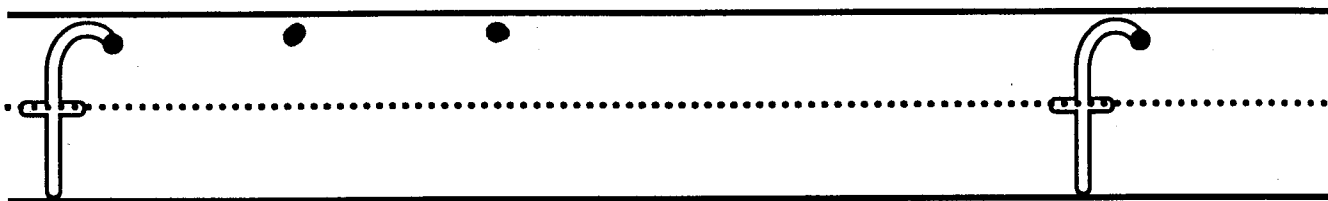

f is tall letter. It starts below the line above, at 2. Go up and around the top to 10. Pull straight down to the base line. Lift the pencil to put a tiny cross in the direction in which we write.

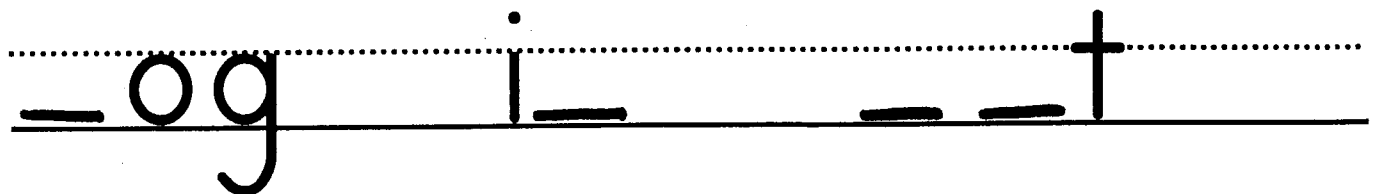
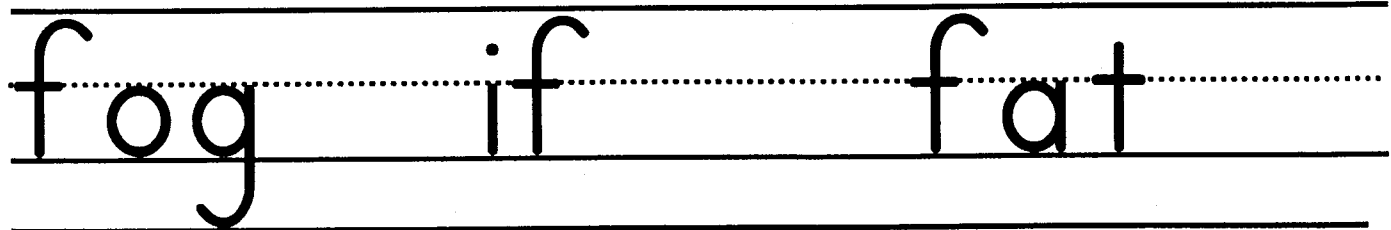
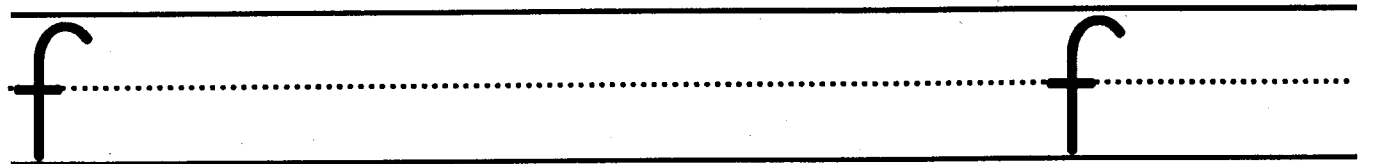
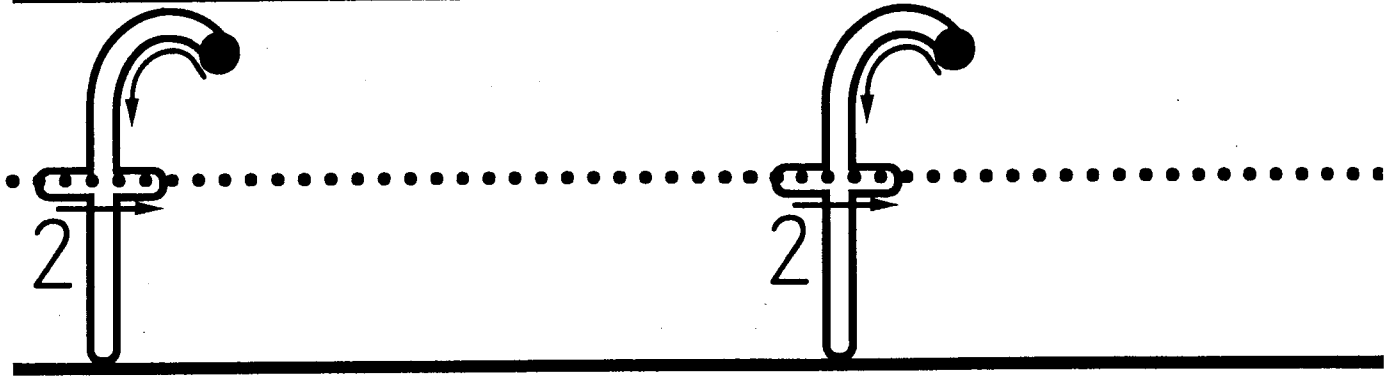

Spalding Lower-case Manuscript Letters

Rules: All letters sit on a base line. Letters are either tall or short.

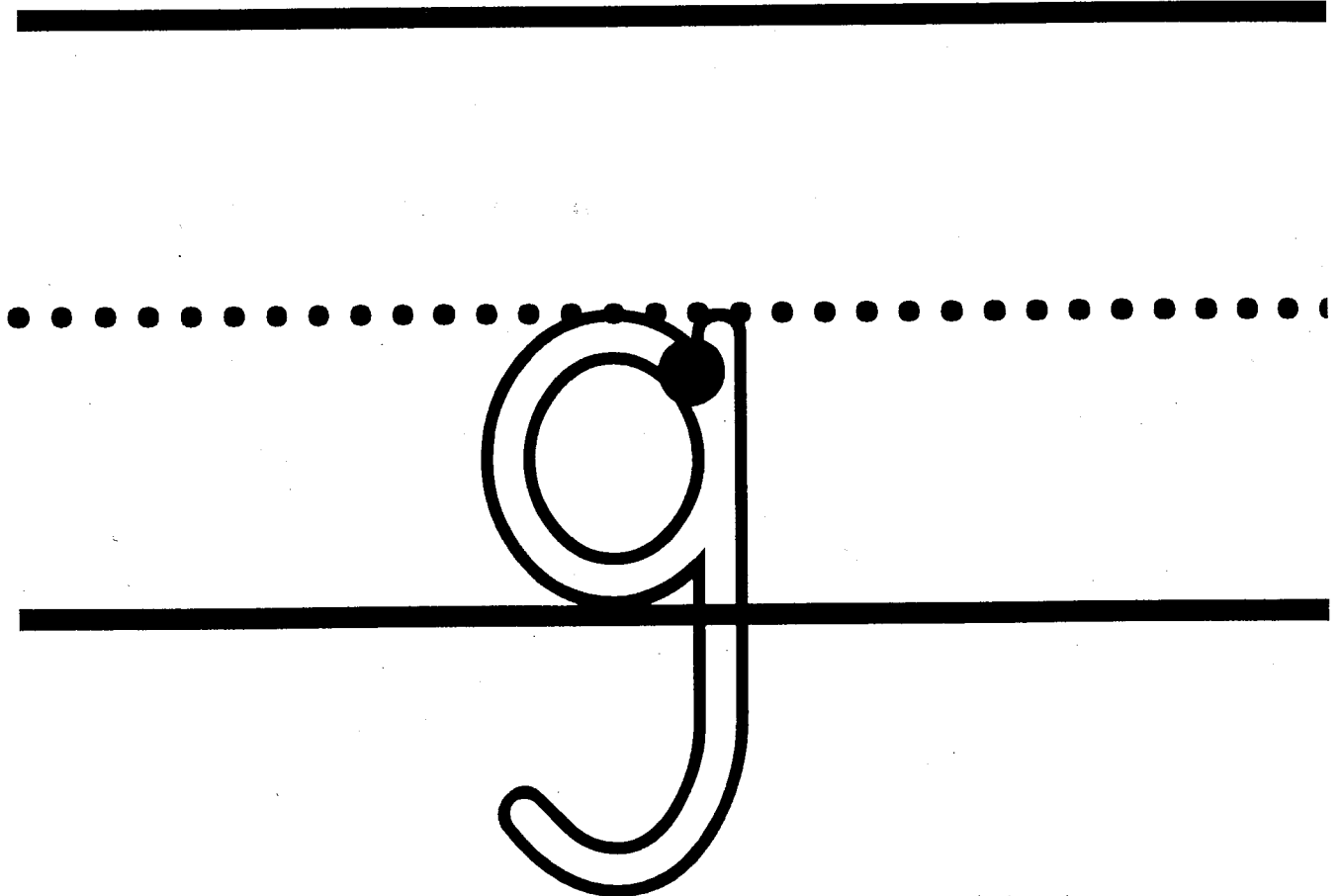
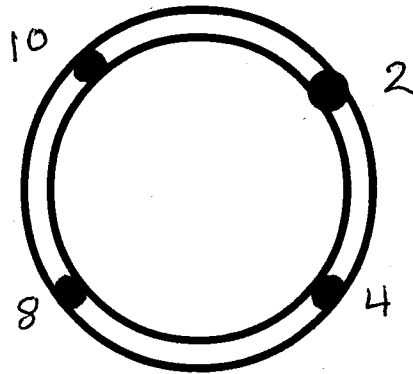

This short letter starts at 2. Go up and around the clock to 2 and make a line down below the base line so this part is the same size as the part above the line. Round it from 4 to 8. A short letter should be able to sit beneath g without touching it.

Spalding Lower-case Manuscript Letters

Rules: All letters sit on a base line. Letters are either tall or short.

This Short letter starts at 2. Go up and around the clock to 2 and make a line down below the base line. Round it from 4 to 8..

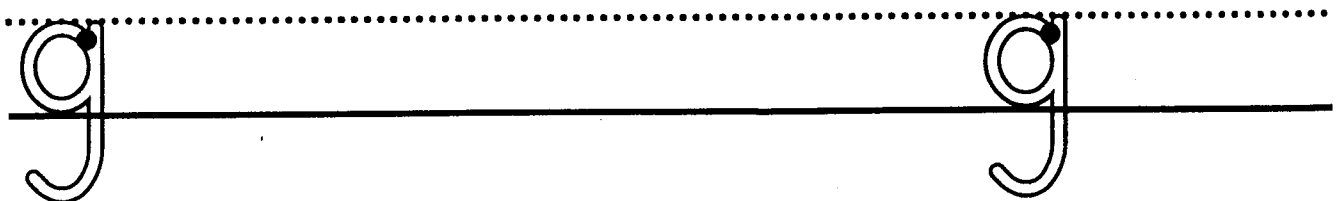
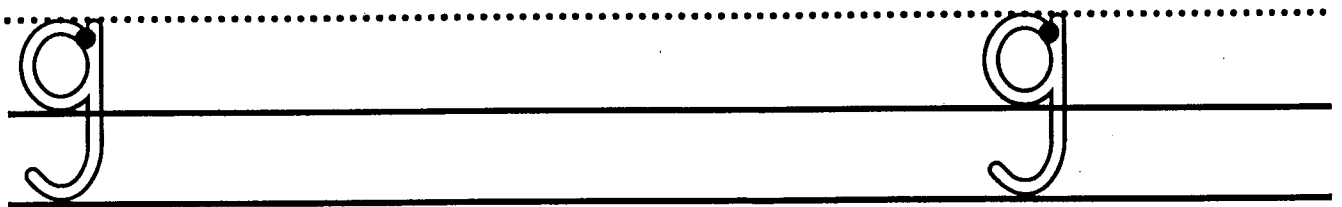
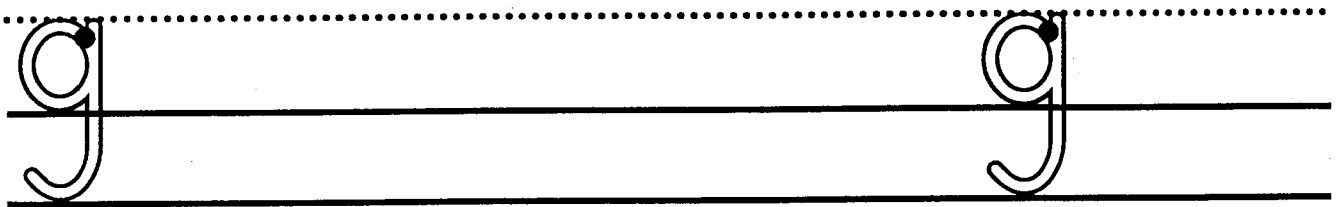
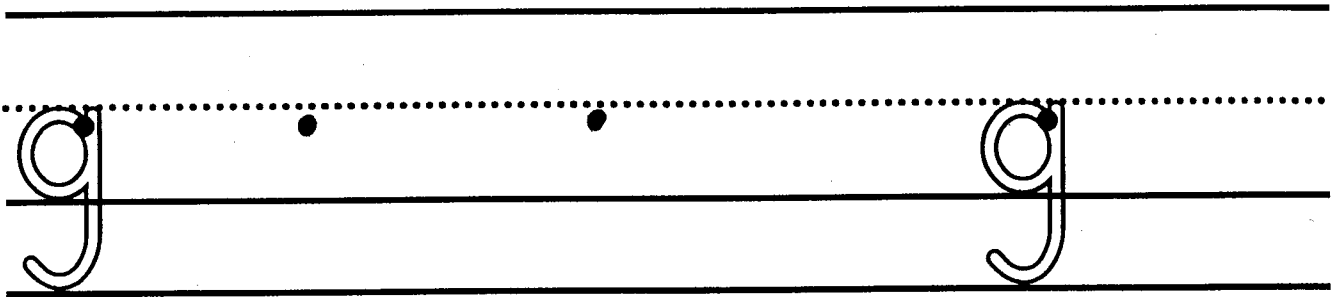
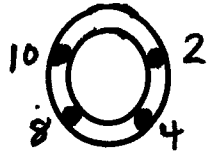

This short letter starts at 2. Go up and around the clock to 2 and make a line down below the base line so this part is the same size as the part above the line. Round it from 4 to 8.

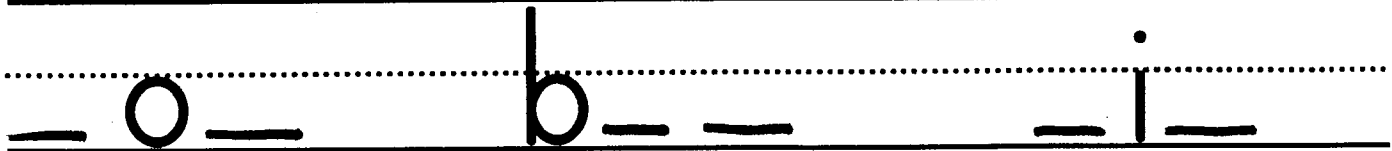
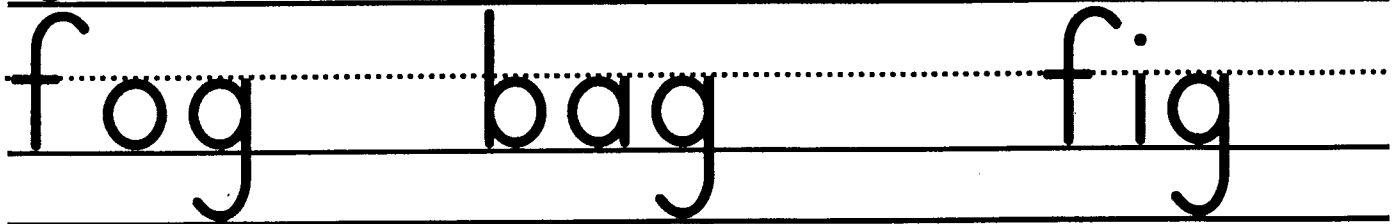
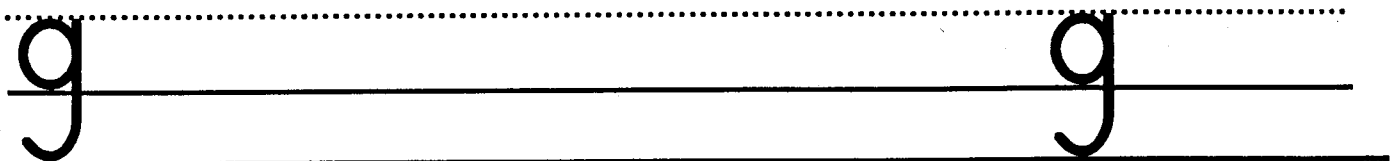
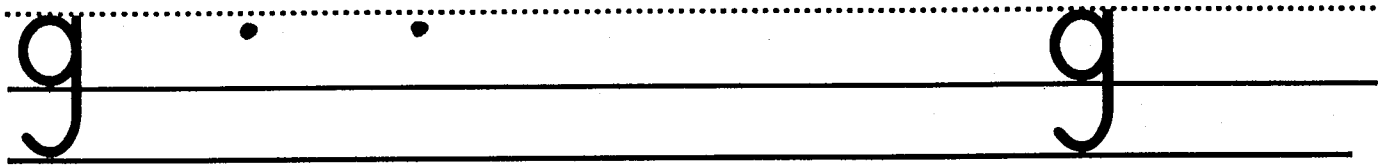
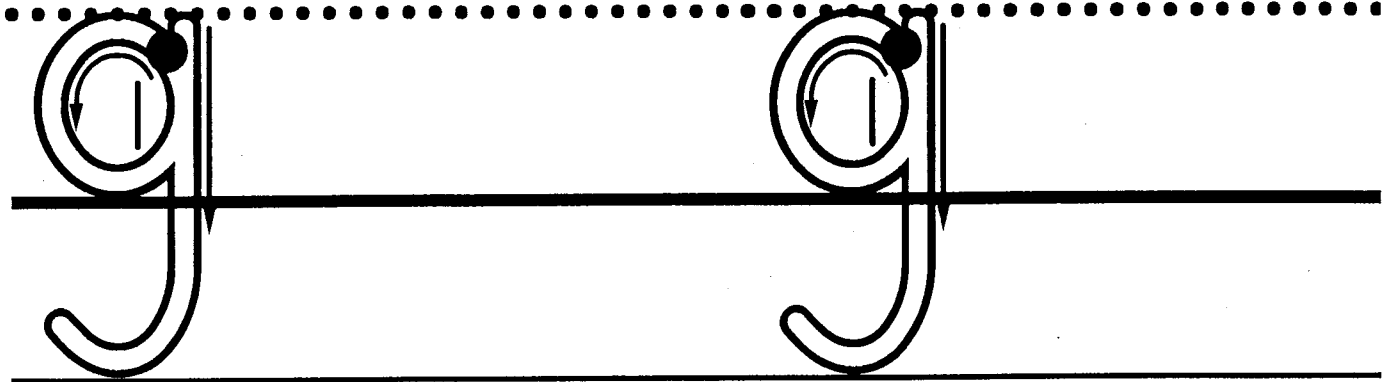

Spalding Lower-case Manuscript Letters

Rules: All letters sit on a base line. Letters are either tall or short.

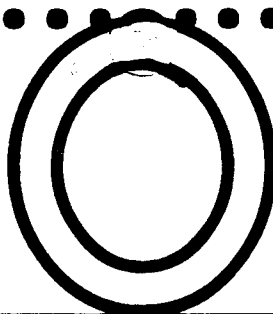
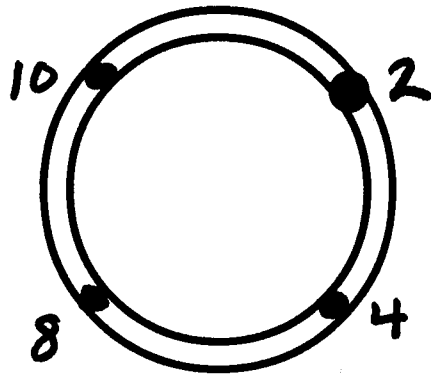

This is a short letter. It starts at 2, goes up and around and closes at 2. Make it sit on the line.

Spalding Lower-case Manuscript Letters

Rules: All letters sit on a base line. Letters are either tall or short.

This is a short letter. It starts at 2, goes up and around and closes at 2. Make it sit on the line.

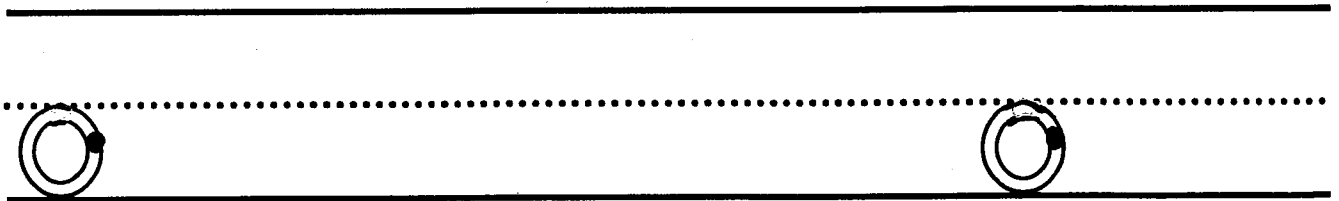
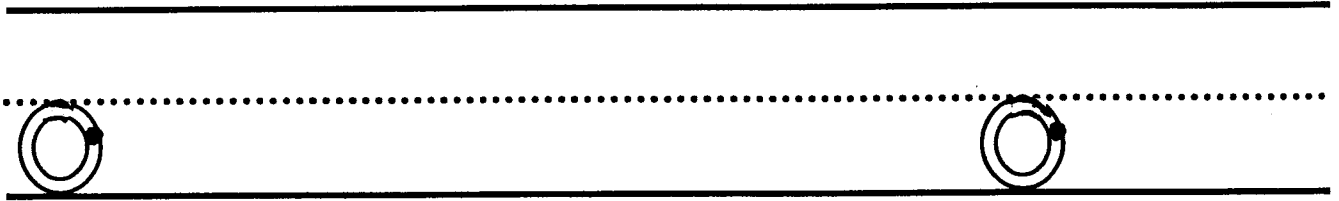
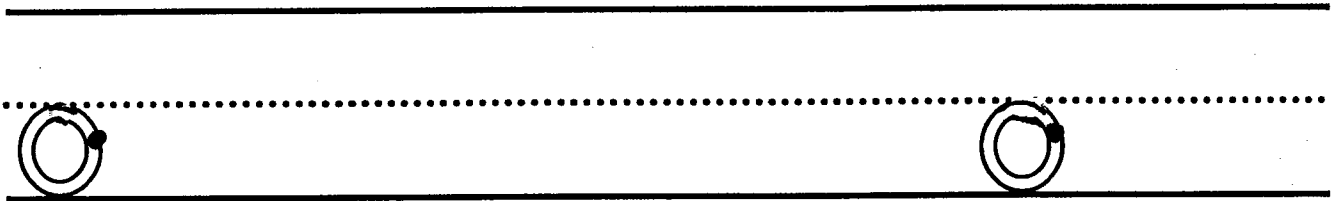
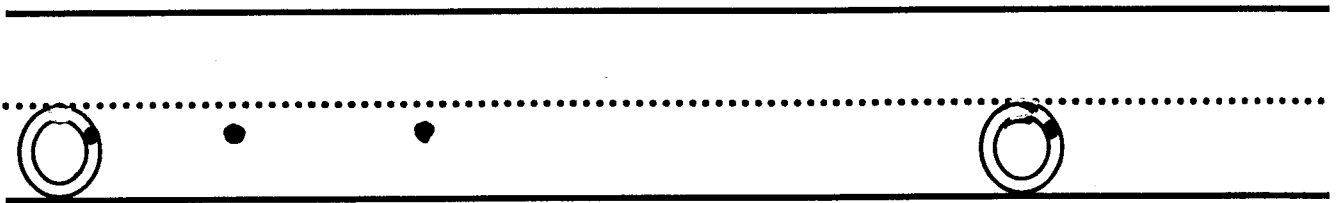

This is a short letter. It starts at 2, goes up and around and closes at 2. Make it sit on the line..

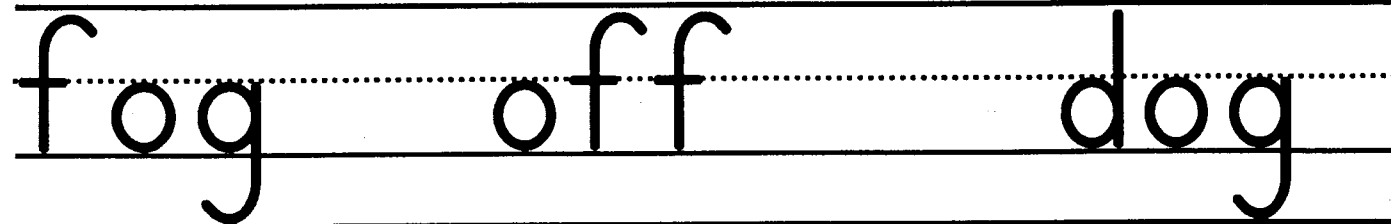
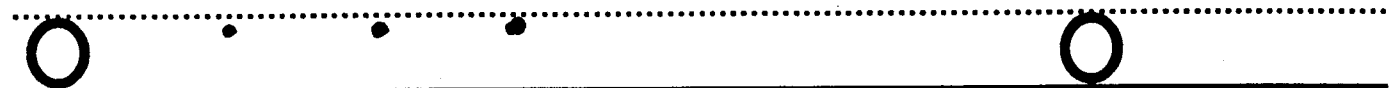

Spalding Lower-case Manuscript Letters

Rules: All letters sit on a base line. Letters are either tall or short.

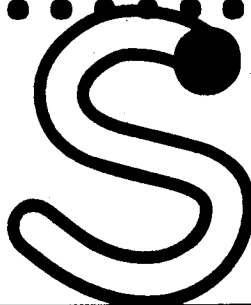
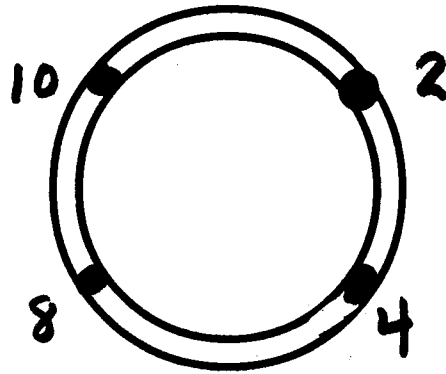

This is a short letter. It starts at 2, goes up around to 10, slides across to 4 and back around to 8.

Spalding Lower-case Manuscript Letters

Rules: All letters sit on a base line. Letters are either tall or short.

This is a short letter. It starts at 2, goes up and around to 10, slides across to 4 and back around to 8.

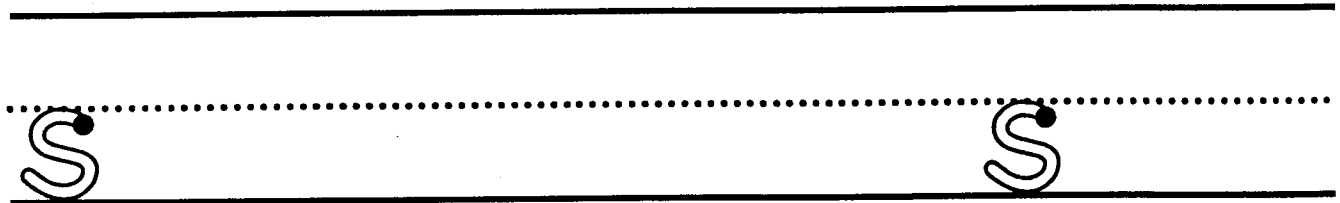
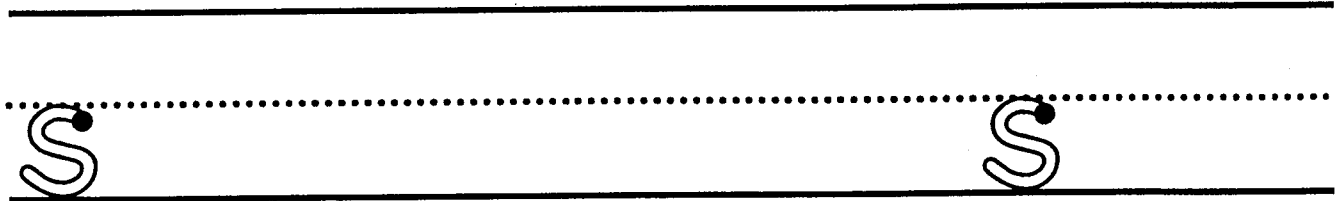
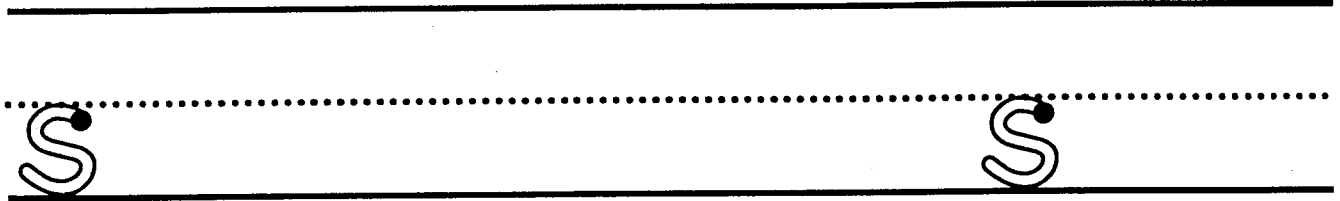
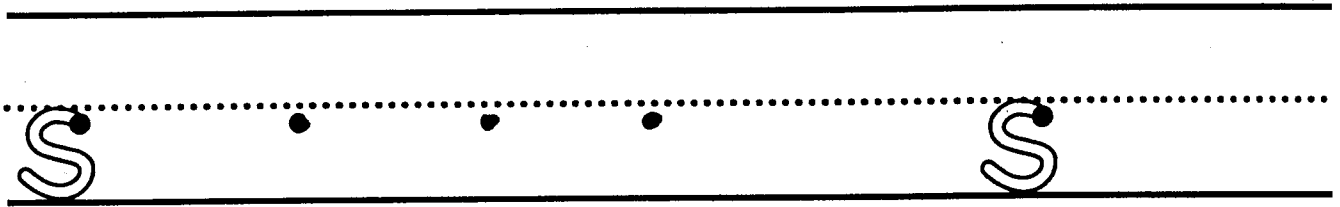
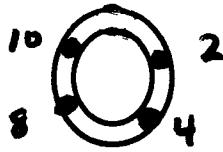

This is a short letter. It starts at 2, goes up around to 10, slides across to 4 and back around to 8.

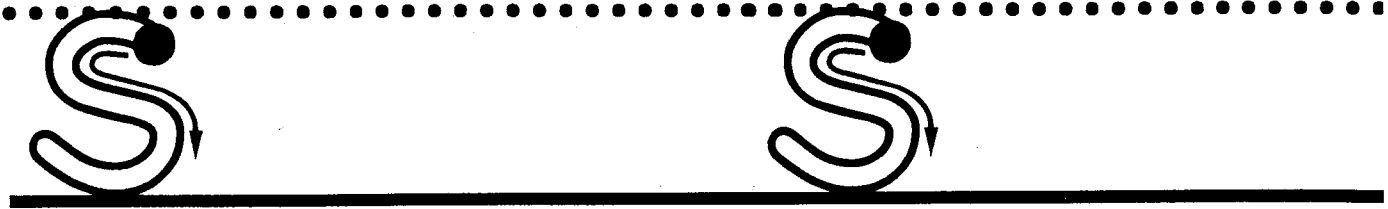

s s

s s

sad sag dogs

Spalding Lower-case Manuscript Letters

Rules: All letters sit on a base line. Letters are either tall or short.

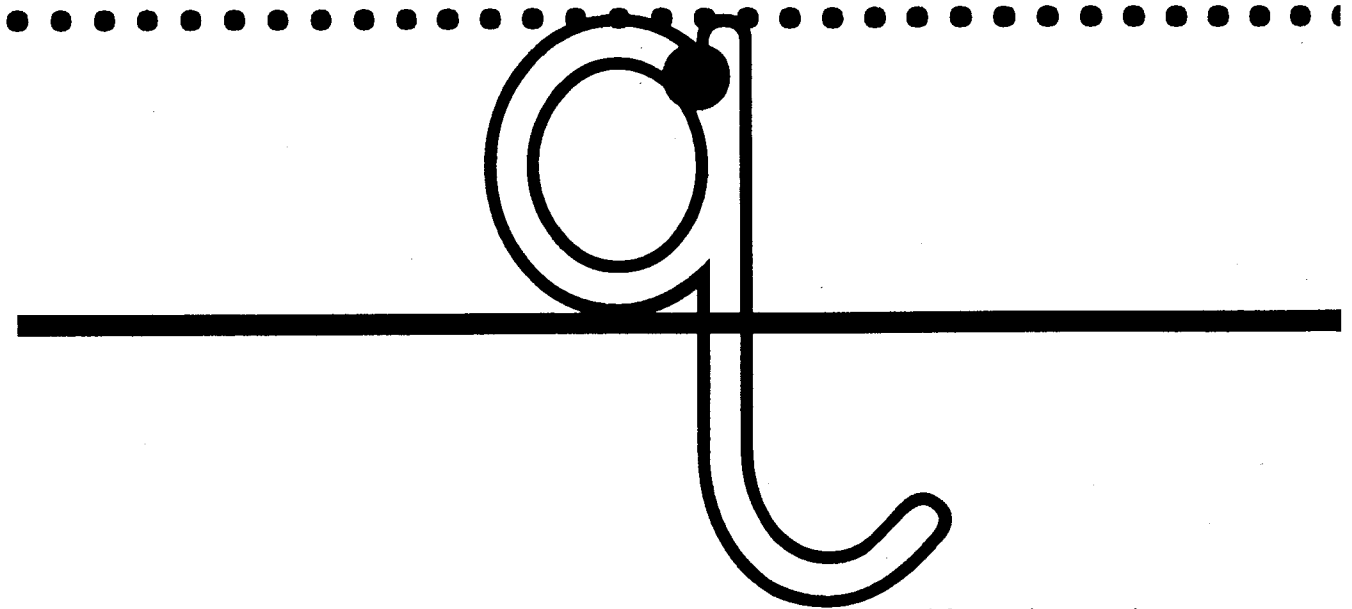
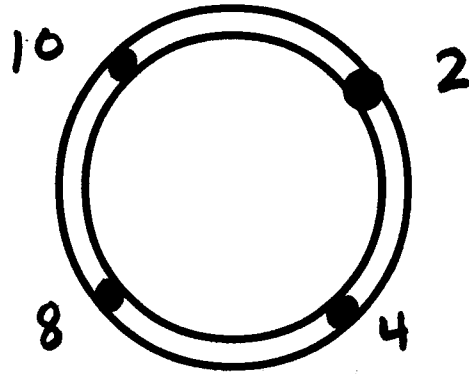

This is a short letter. It starts at 2, goes up around to 2. Without lifting the pencil make a straight line go below the base line. Make a tiny flag in the direction in which we write.

Spalding Lower-case Manuscript Letters

Rules: All letters sit on a base line. Letters are either tall or short.

This is a short letter. It starts at 2, goes up and around to 2. Make a straight line go below the base line. Make a tiny flag in the direction in which we write.

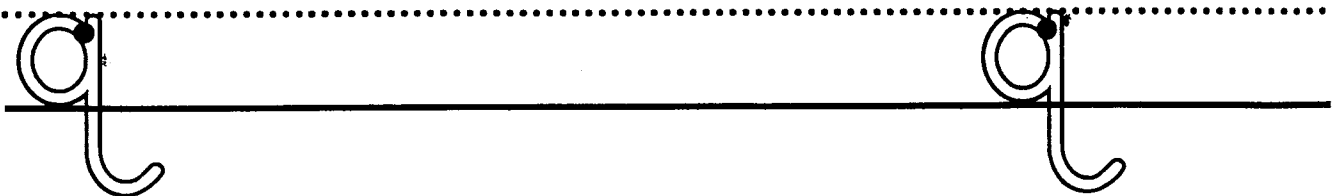
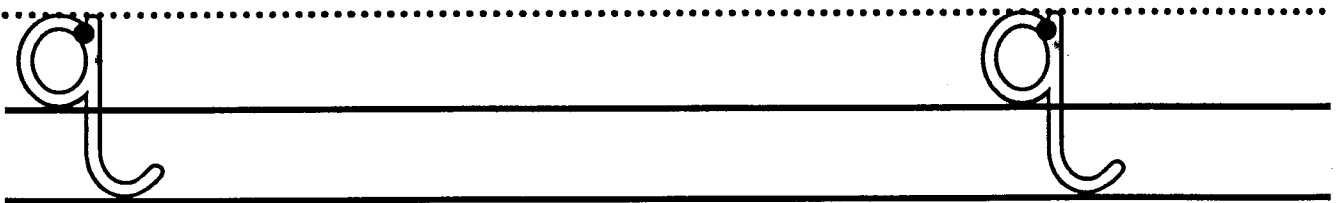
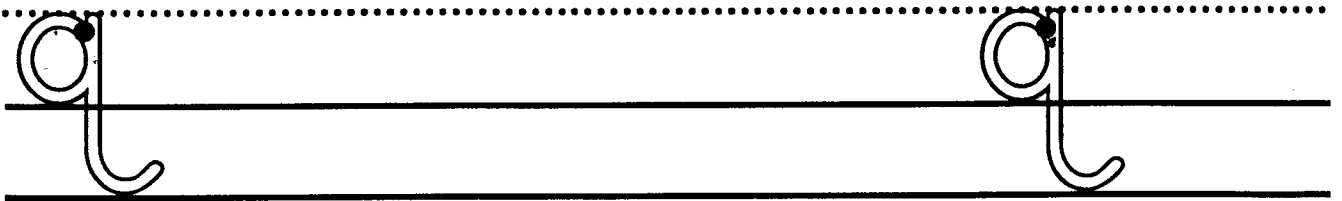
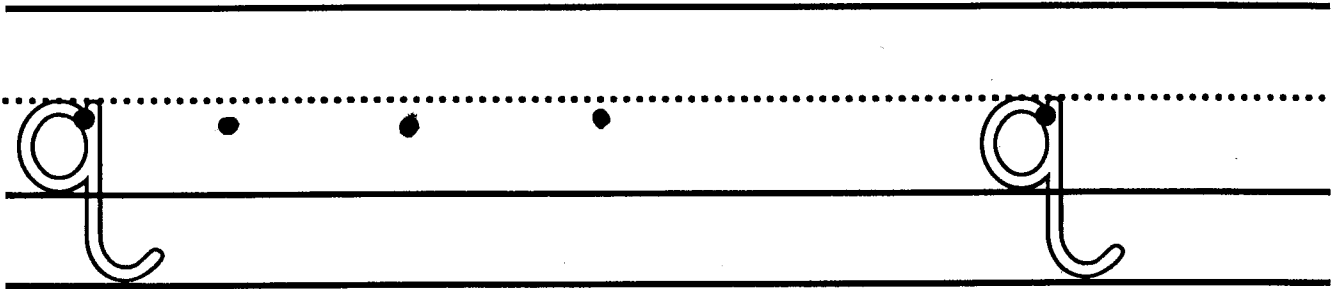
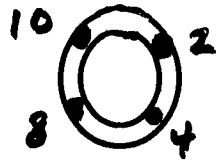

This is a short letter. It starts at 2, goes up and around to 2. Without lifting the pencil make a straight line go below the base line. Make a tiny flag in the direction in which we write.

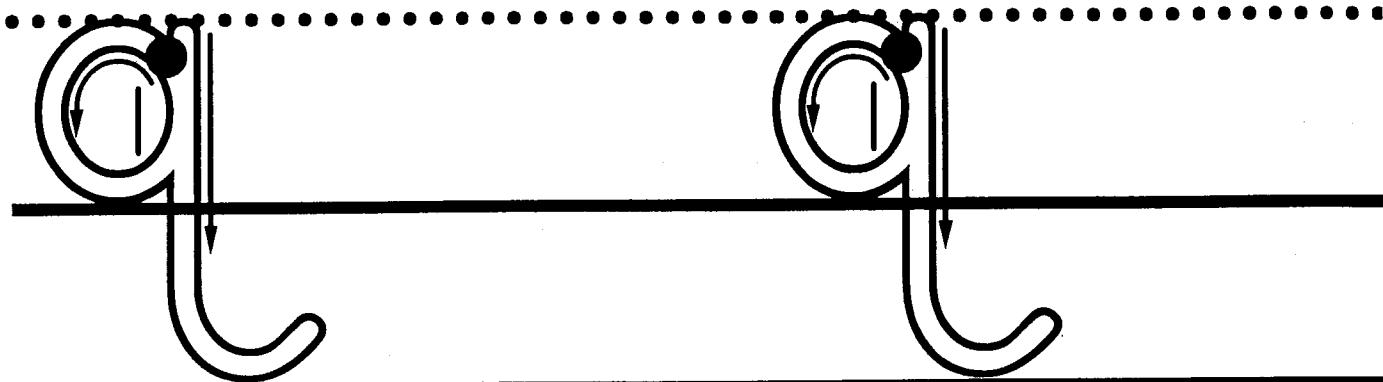

q

q

q

q

queen

quick

_queen

_ui_k

Spalding Lower-case Manuscript Letters

Rules: All letters sit on a base line. Letters are either tall or short.

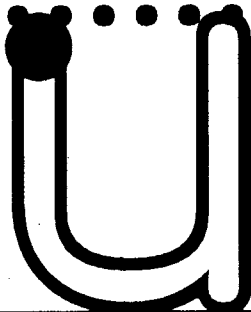
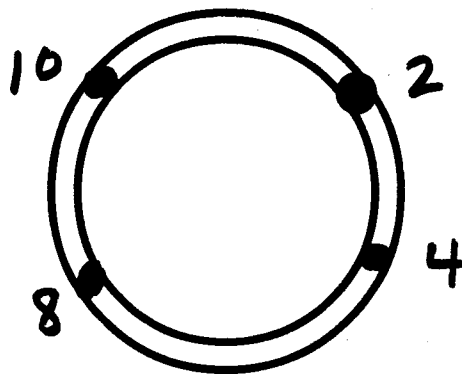

This is a short letter. It starts with a line at the top. Bring the line almost to the base line and round it from 8 to 4. Continue up with a straight line and retrace with a line to the base line.

Spalding Lower-case Manuscript Letters

Rules: All letters sit on a base line. Letters are either tall or short.

This is a short letter. It starts with a line at the top. Bring the line almost to the base line and round it from 8 to 4. Continue up with a straight line and retrace with a line to the base line.

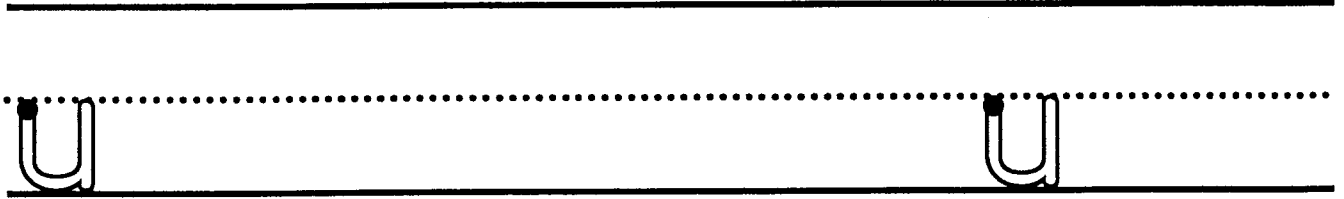
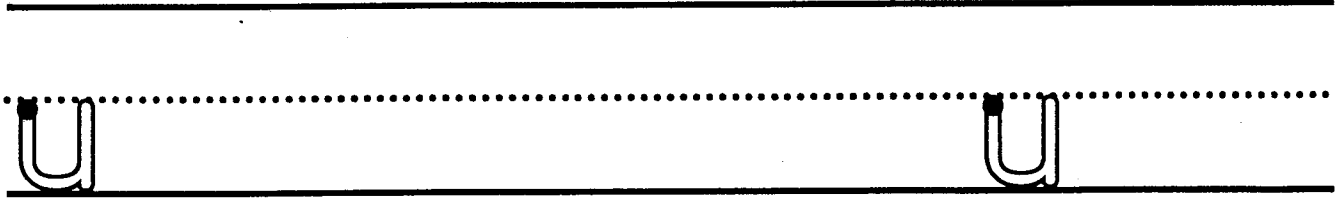
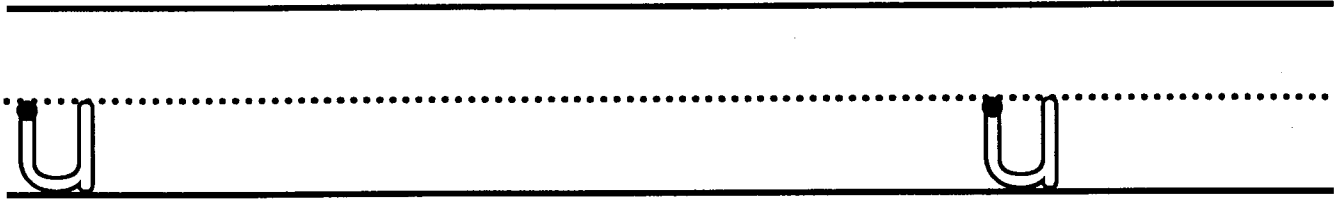
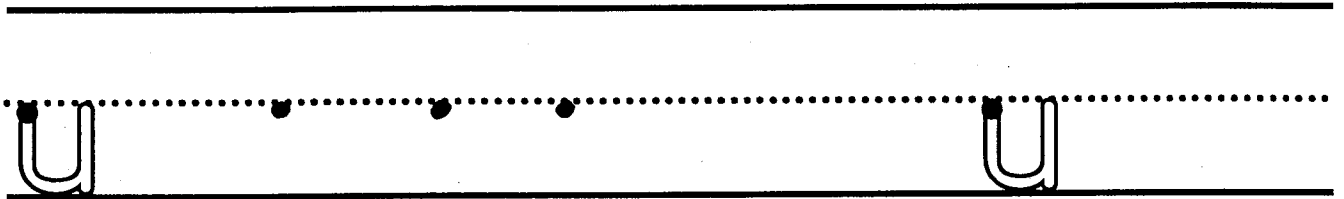

This is a small letter. It starts with a line at the top. Bring the line almost to the base line and round it from 8 to 4. Continue up with a straight line and retrace with a line to the base line.

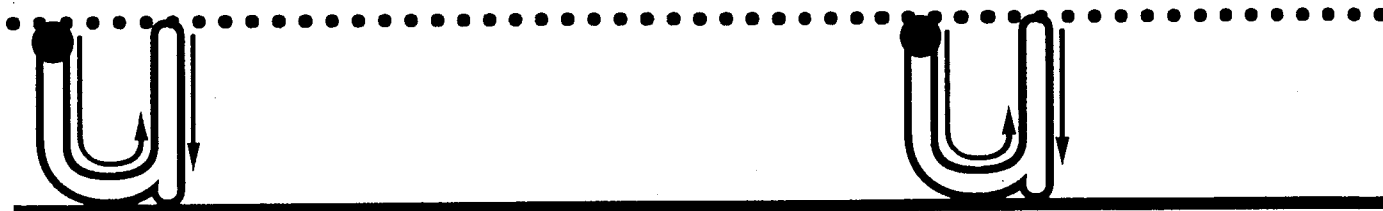

u



u

u

u

queen

quick

— — een

— — ick

Spalding Lower-case Manuscript Letters

Rules: All letters sit on a base line. Letters are either tall or short.

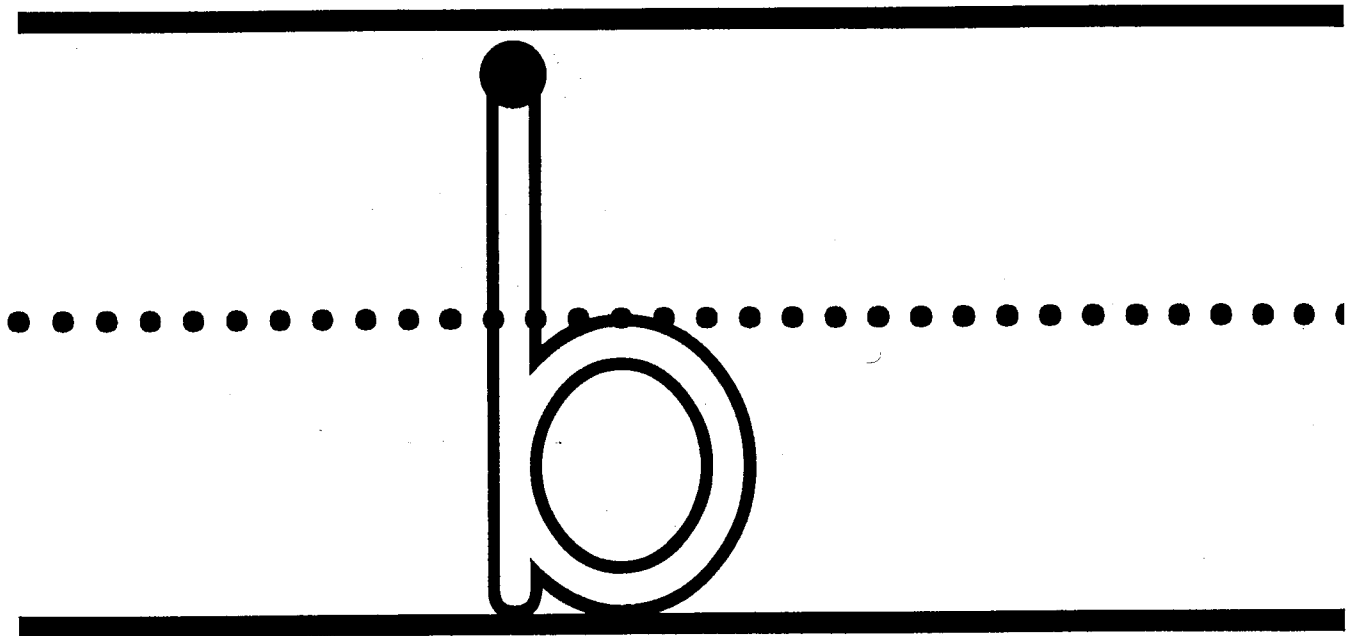
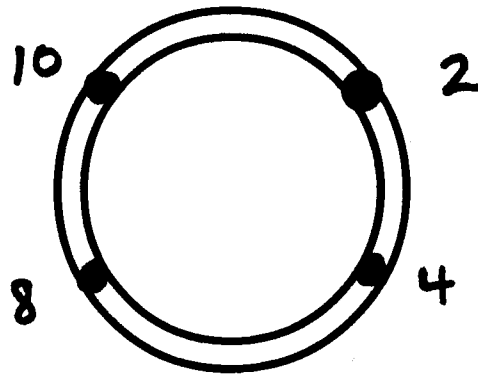

This is a tall letter with a short part. Start at the top and pull the pencil down to the base line. Then, without lifting the pencil, go back up almost halfway to the line above and make the round short part starting from 10 and rounding to 8 on the clock.

Spalding Lower-case Manuscript Letters

Rules: All letters sit on a base line. Letters are either tall or short.

This is a tall letter with a short part. Start at the top and pull the pencil down to the base line. Then without lifting the pencil, go back up halfway to the line above and make the round short part starting from 10 and rounding to 8 on the clock.

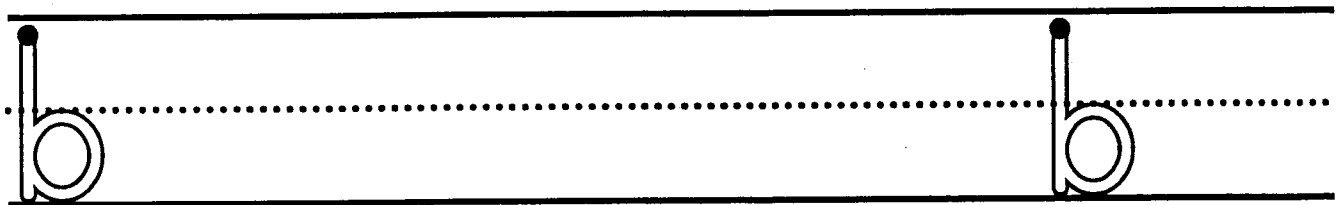
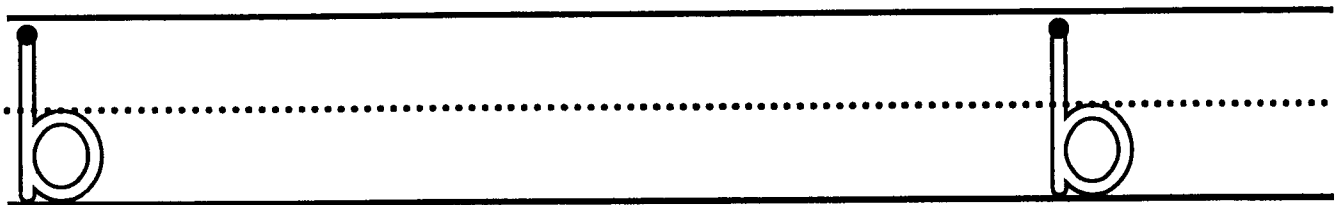
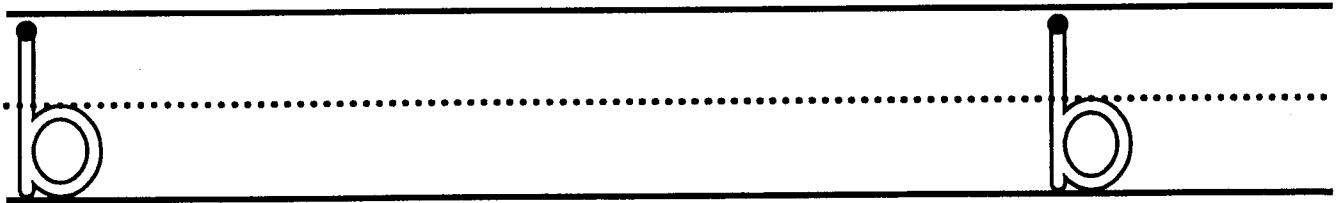
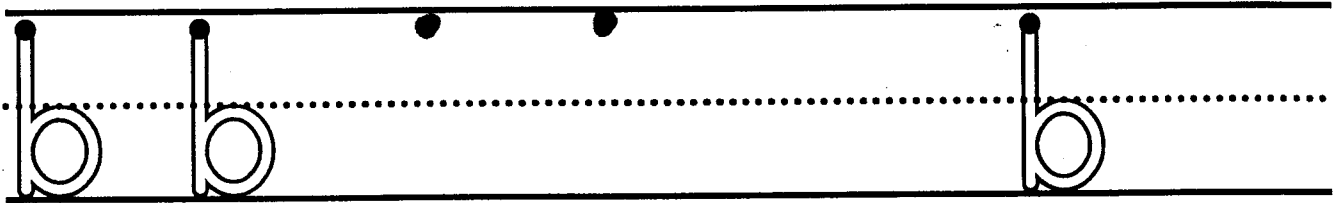
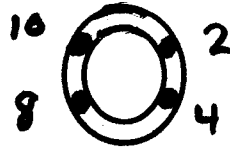

This is a tall letter with a short part. Start at the top and pull the pencil down to the base line. Then without lifting the pencil, go back up halfway to the line above and make the round short part starting from 10 and rounding to 8 on the clock.

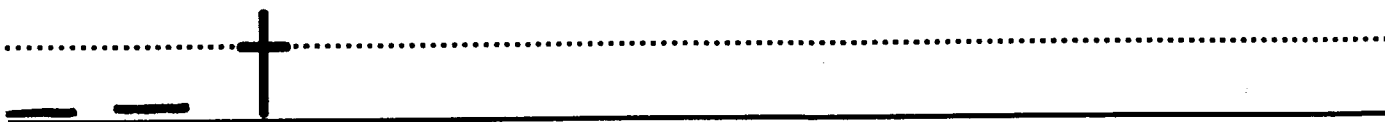
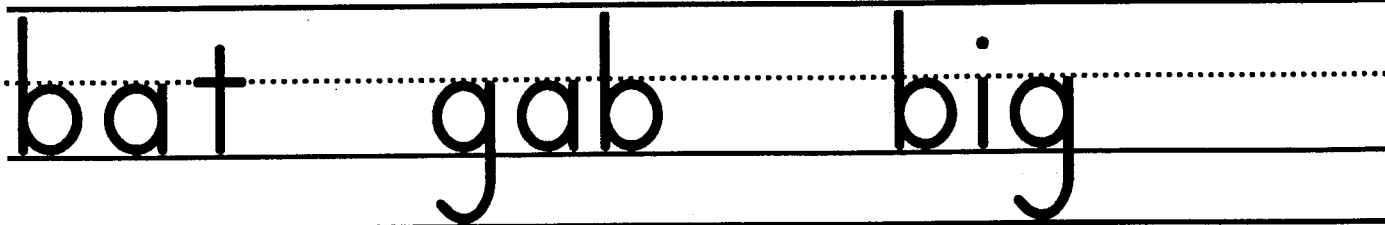
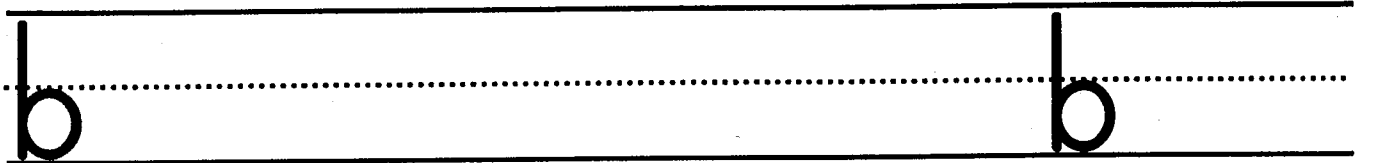
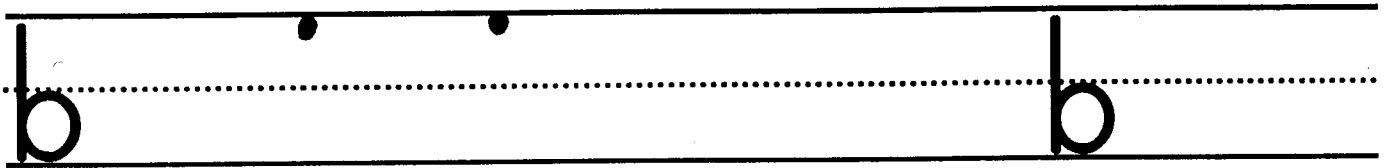
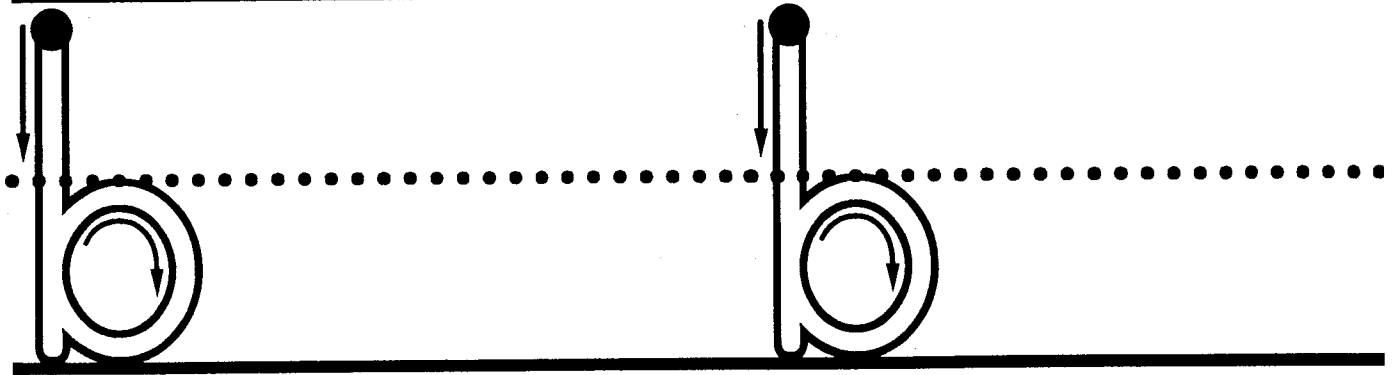

Spalding Lower-case Manuscript Letters

Rules: All letters sit on a base line. Letters are either tall or short.

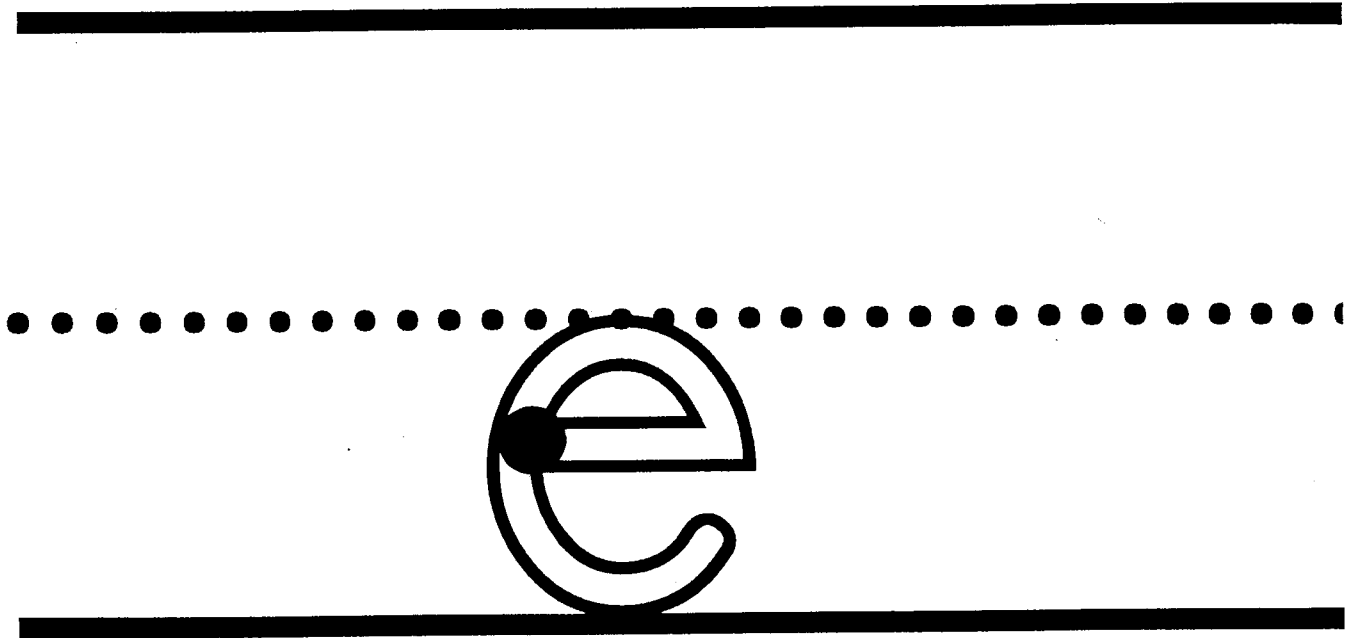
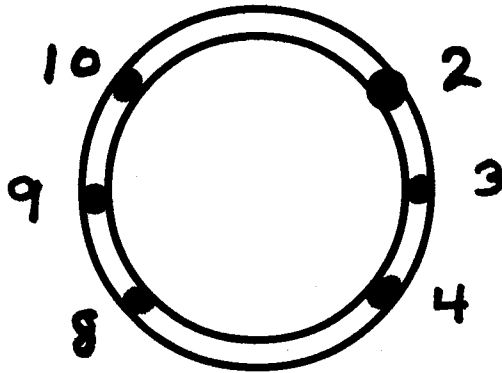

This letter is short. It starts with a line drawn from 9 to 3 through the clock. Continue up around the clock from 3 and stop at 4.

Spalding Lower-case Manuscript Letters

Rules: All letters sit on a base line. Letters are either tall or short.
This letter is short. It starts with a line drawn from 9 to 3 through the clock.
Continue up around the clock from 3 and stop at 4.

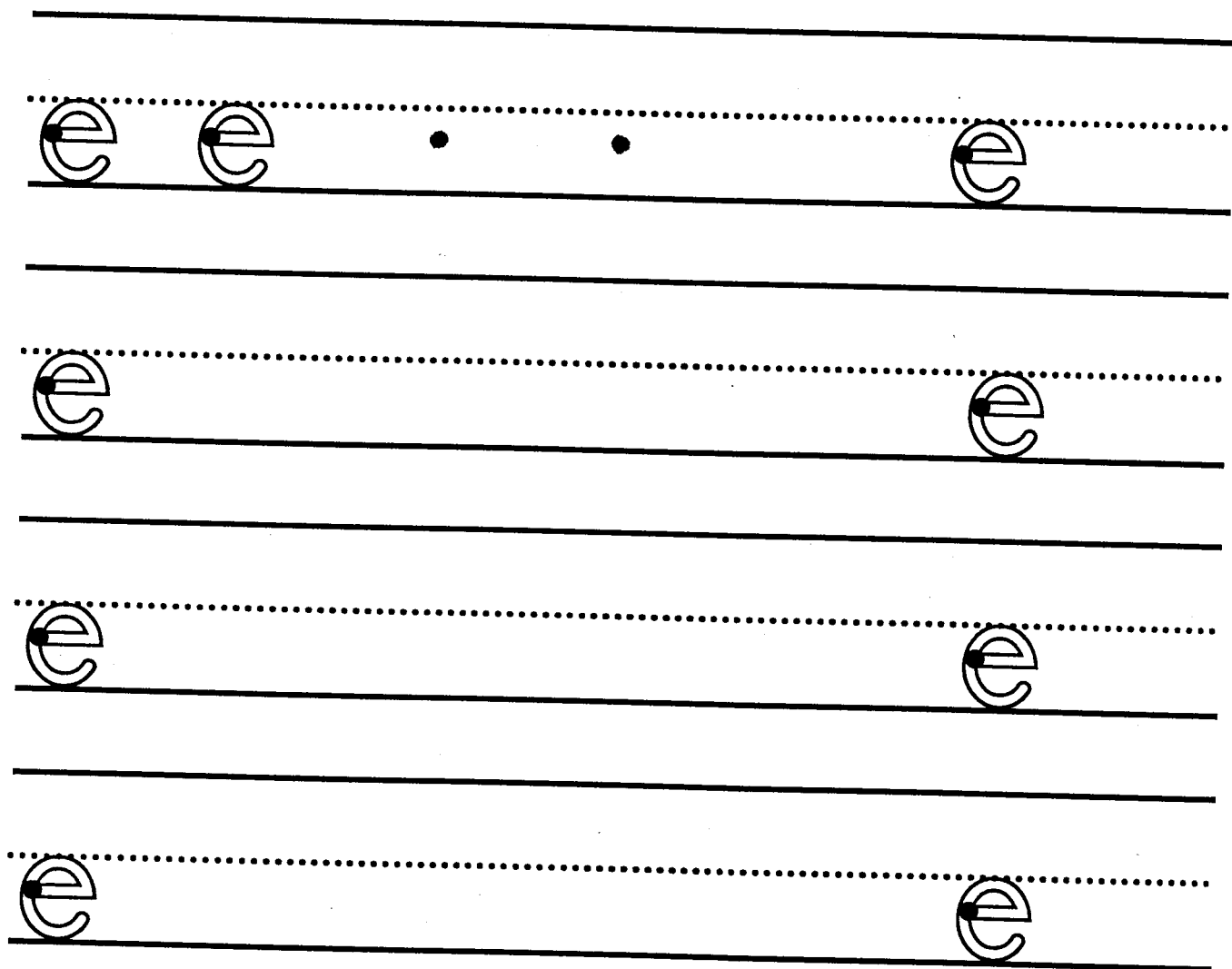

This letter is short. It starts with a line drawn from 9 to 3 through the clock. Continue up around the clock from 3 and stop at 4.

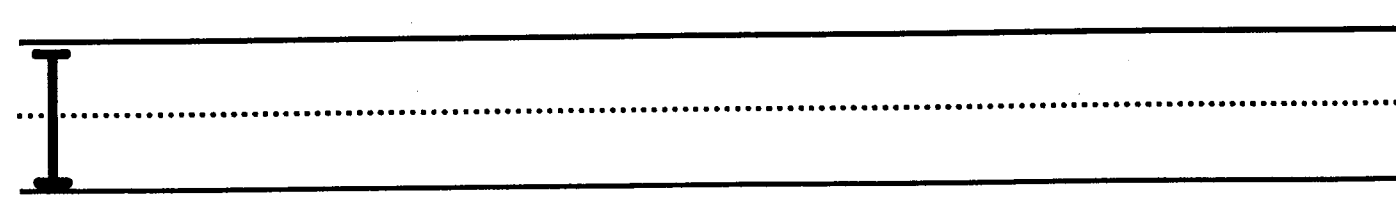
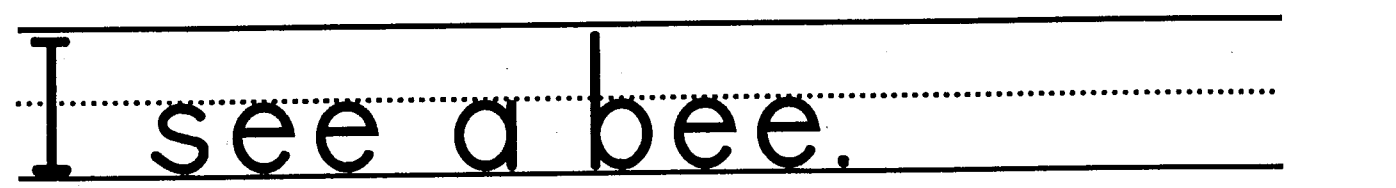
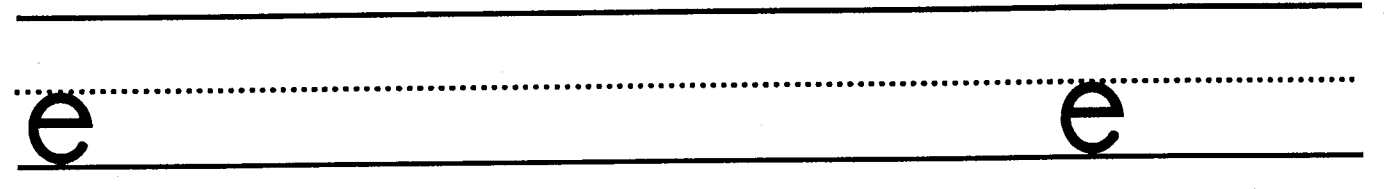
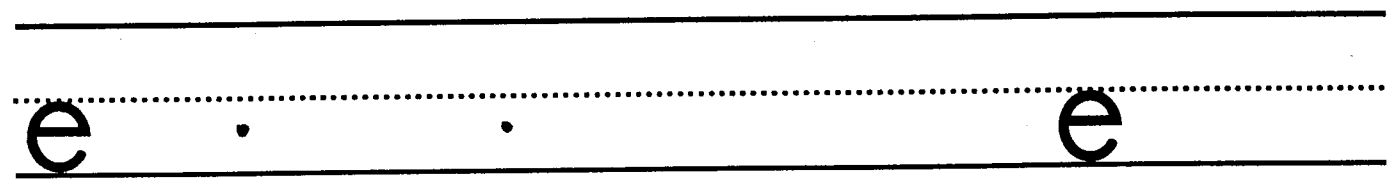
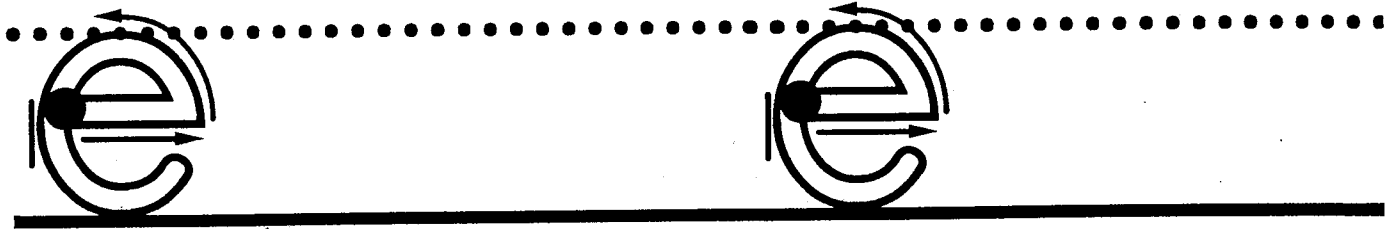

Spalding Lower-case Manuscript Letters

Rules: All letters sit on a base line. Letters are either tall or short.

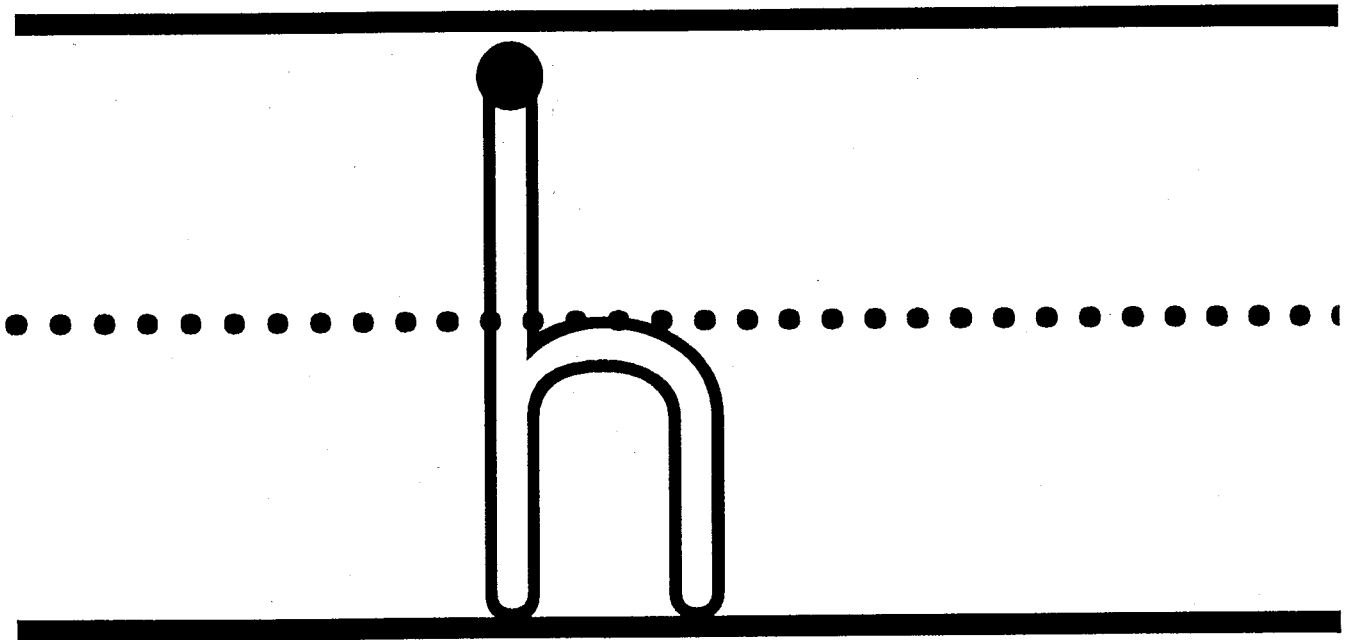
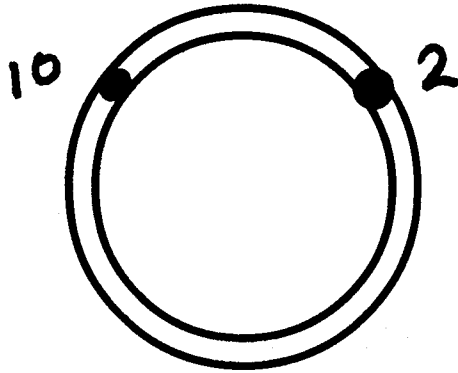

This is a tall letter with a short part. Start at the top and pull the pencil down to the base line. Then go back up halfway and make the round part from 10 to 2 and finish with a down line to the base line.

Spalding Lower-case Manuscript Letters

Rules: All letters sit on a base line. Letters are either tall or short.

This letter is a tall letter with a short part. Start at the top and pull the pencil down to the base line...Then go back up halfway and make the round part from 10 to 2 and finish with a down line to the base line.

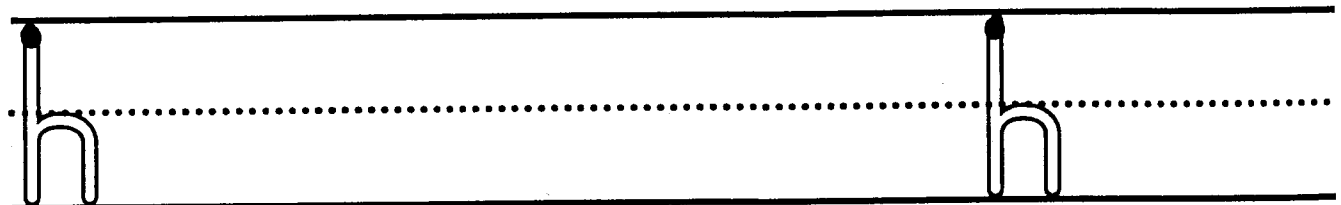
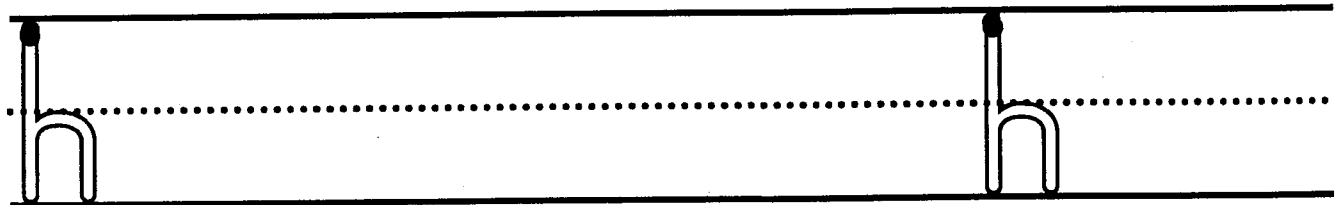
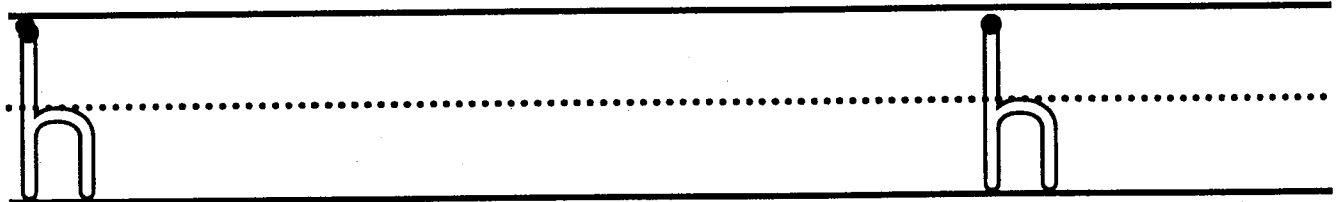
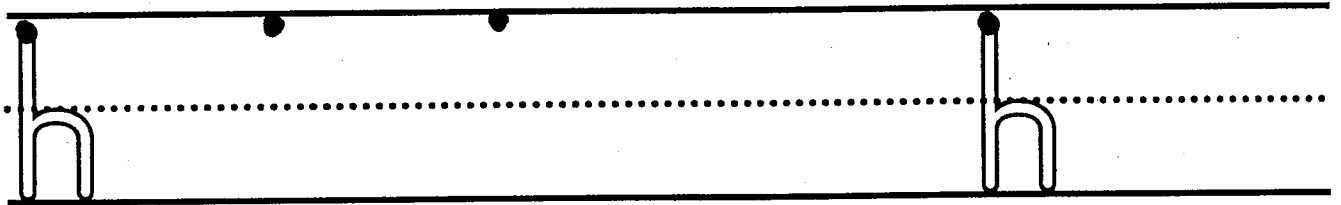
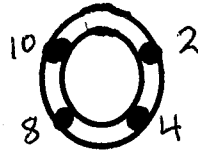

This is a tall letter with a short part. Start at the top and pull the pencil down to the base line. Then go back up halfway and make the round part from 10 to 2 and finish with a down line to the base line.

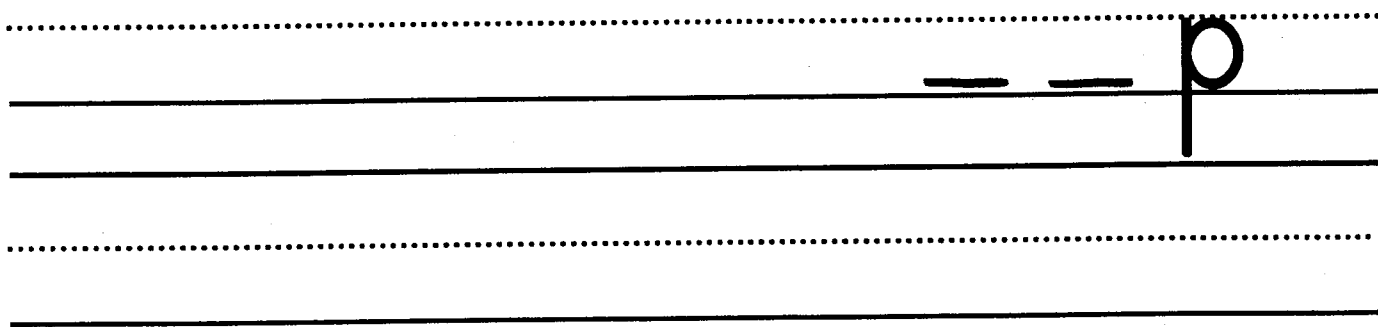
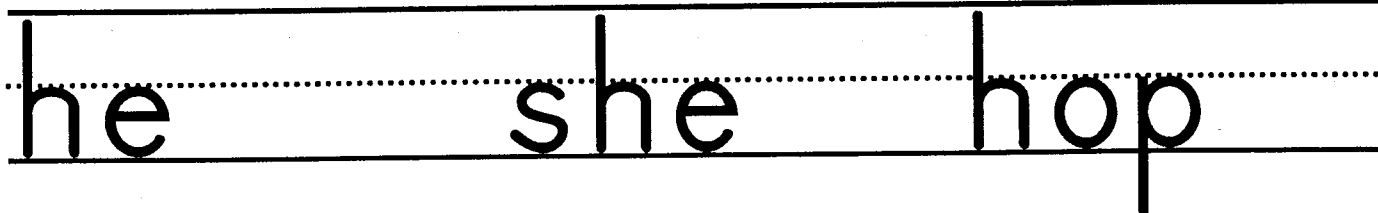
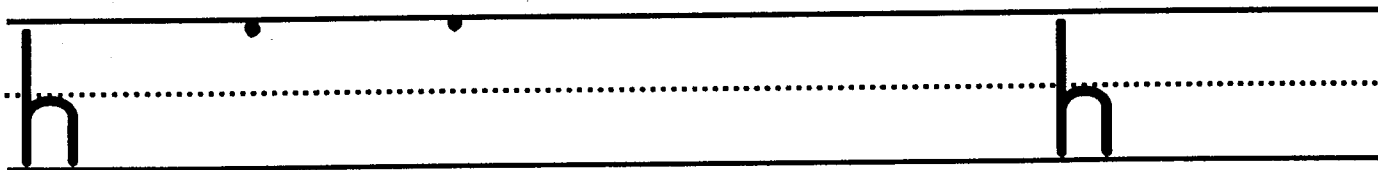
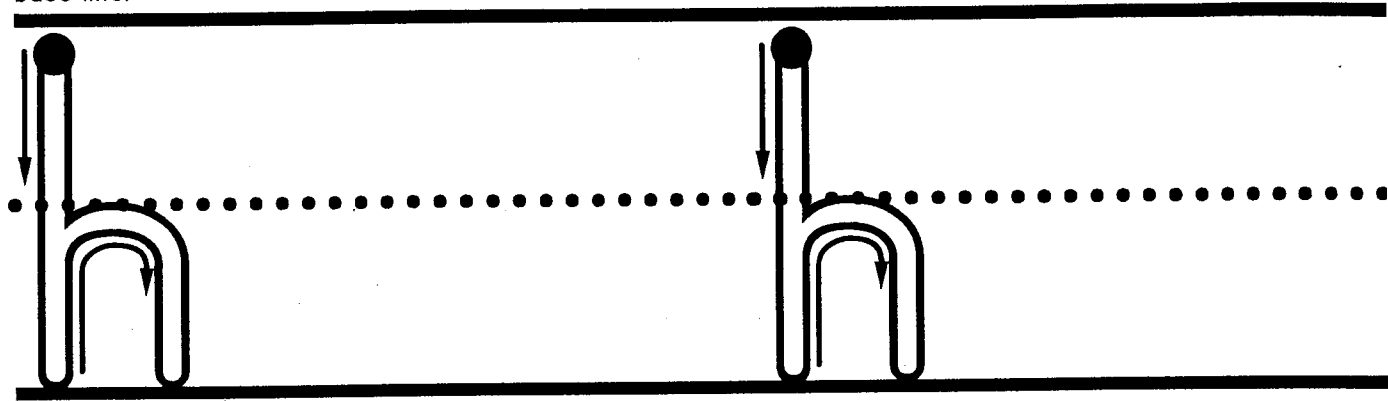

Spalding Lower-case Manuscript Letters

Rules: All letters sit on a base line. Letters are either tall or short.

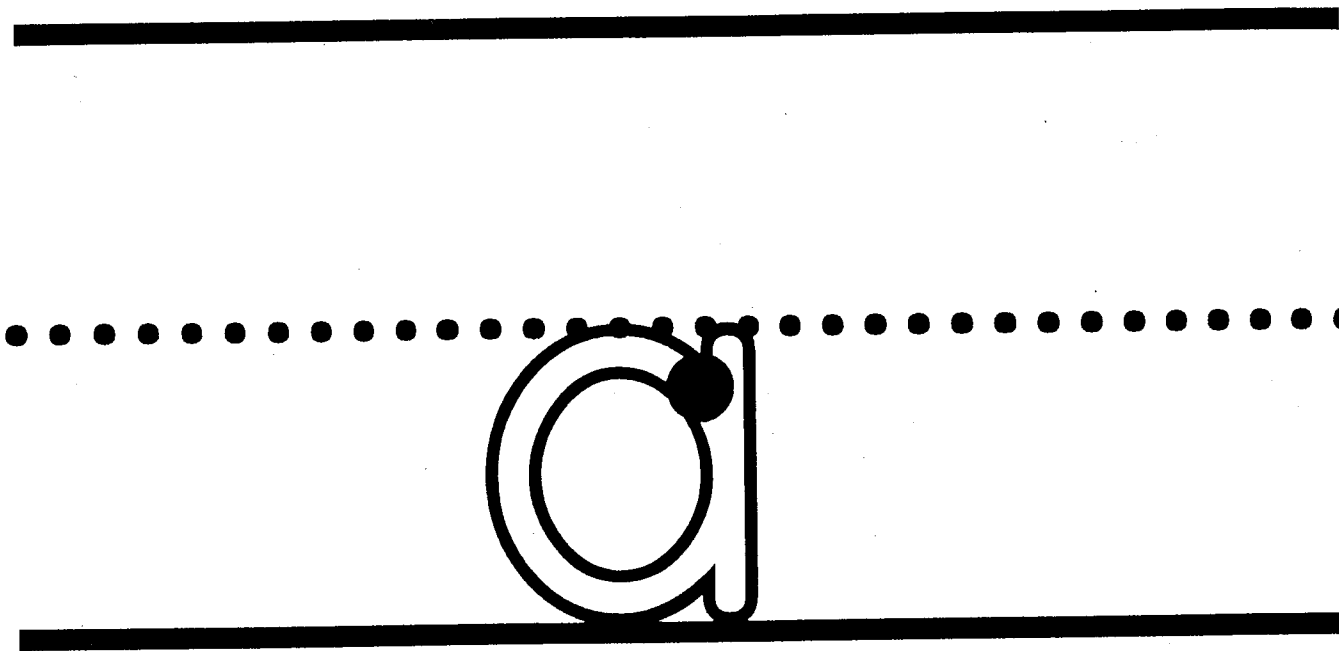
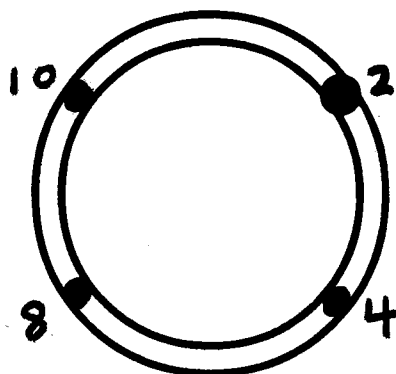

This is a short letter. Begin at 2, go up and around the clock to 2 and, without lifting the pencil, pull a line straight down to the base line.

Spalding Lower-case Manuscript Letters

Rules: All letters sit on a base line. Letters are either tall or short.

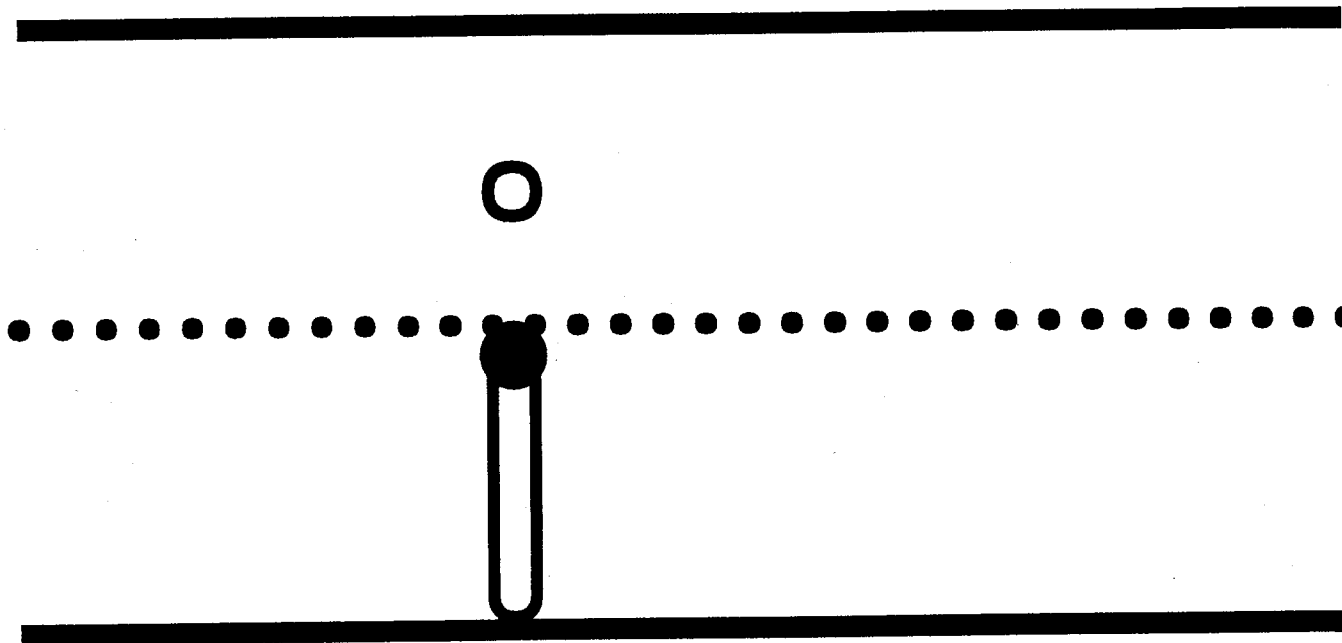

This is a short letter which starts at the middle and goes down. The dot is made last!

Spalding Lower-case Manuscript Letters

Rules: All letters sit on a base line. Letters are either tall or short.

This is a short letter that starts at the middle and goes down. The dot is made last.

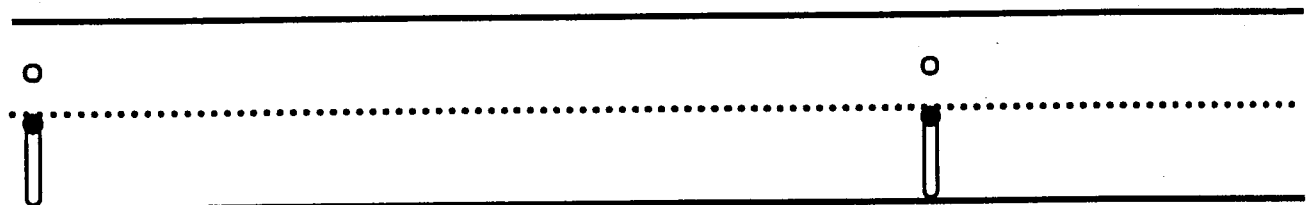
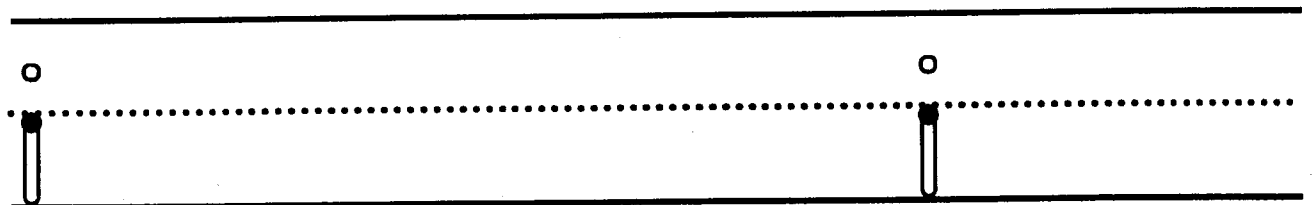
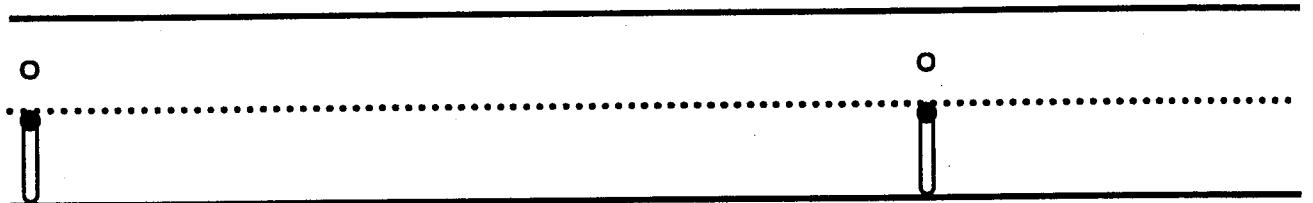
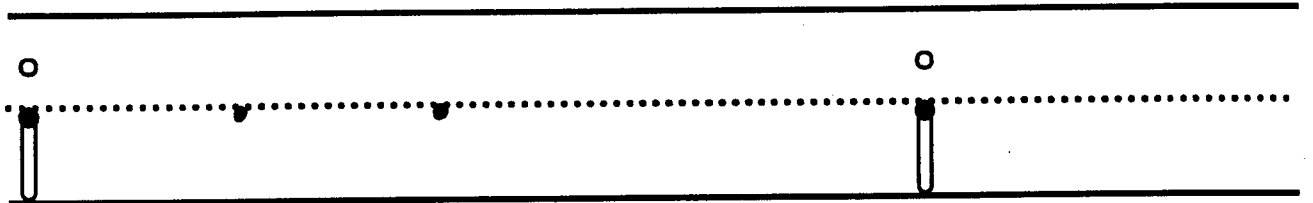

This is a short letter which starts at the middle and goes down. the dot is made last.

o o

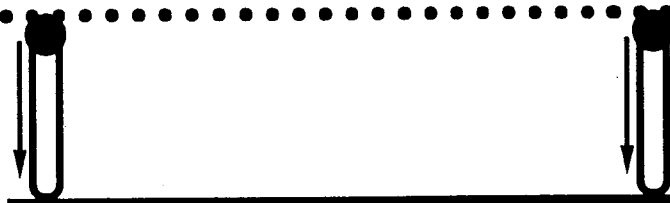

i i

This is his hat.

T _ _ _ _ _ t.

Spalding Lower-case Manuscript Letters

Rules: All letters sit on a base line. Letters are either tall or short.

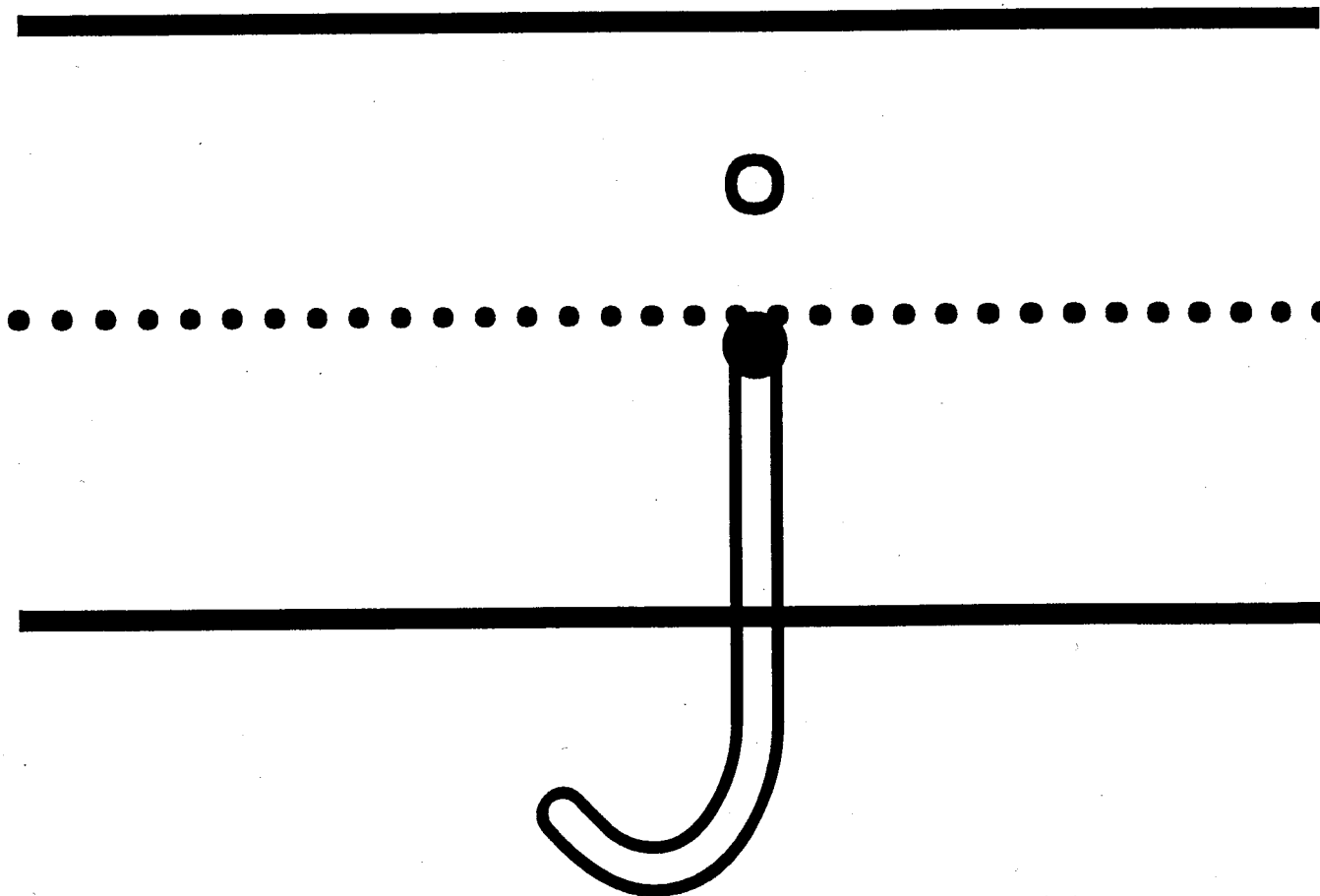
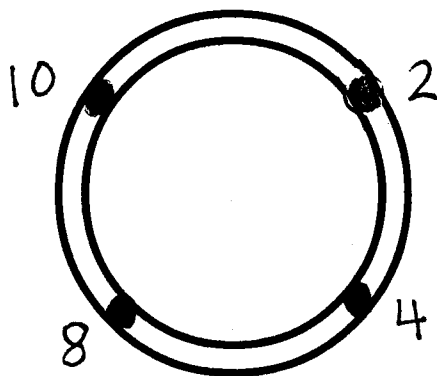

This is a short letter that goes below the base line. Start at the middle and go below the line. Round the bottom part from 4 to 8. The dot is last.

Spalding Lower-case Manuscript Letters

Rules: All letters sit on a base line. Letters are either tall or short.

This is a short letter that goes below the base line. Start at the middle and go below the line. Round the bottom part from 4 to 8. The dot is last..

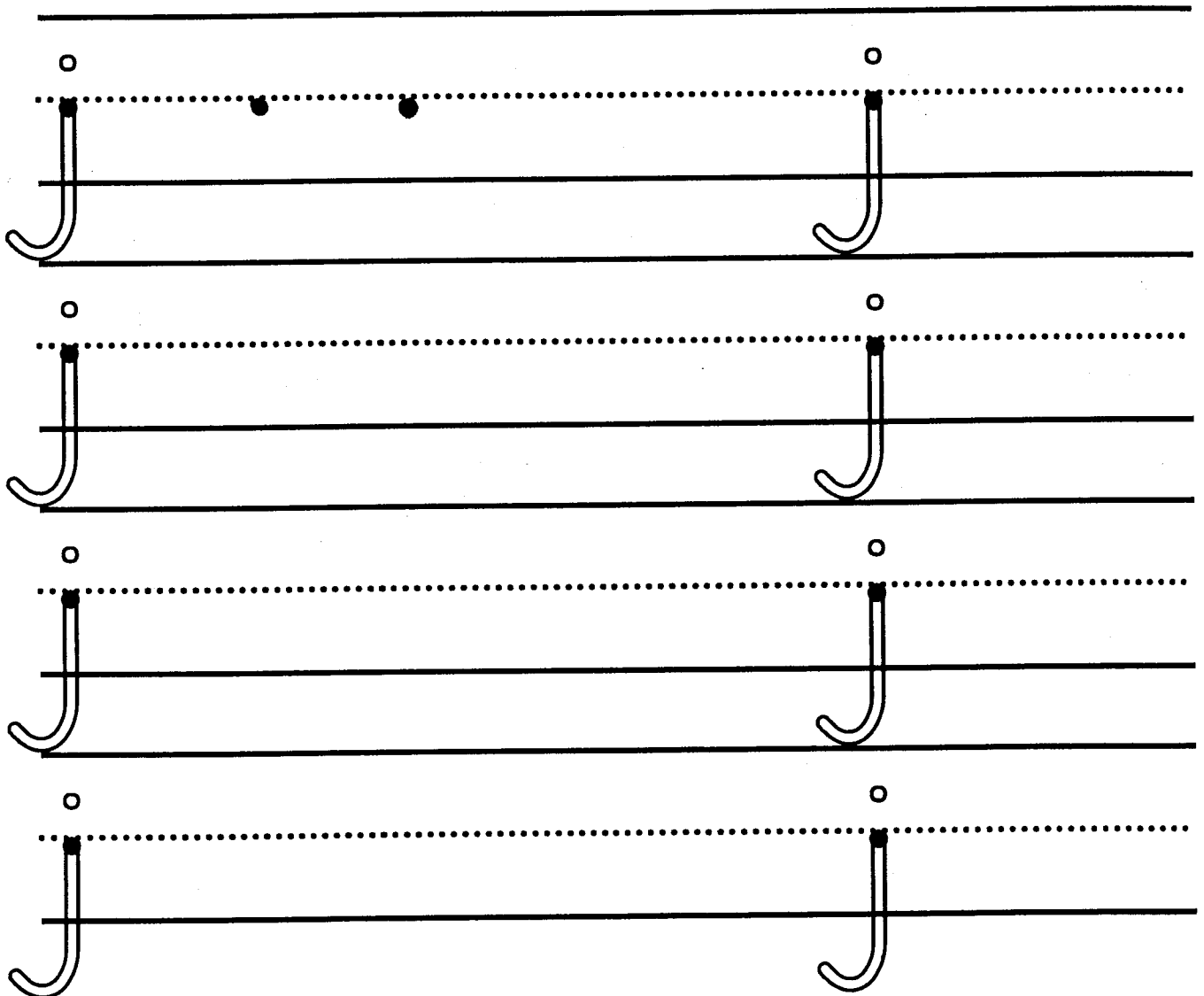
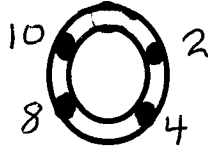

This is a short letter that goes below the base line. Start at the middle and go below the line. Round the bottom part from 4 to 8. the dot is last.

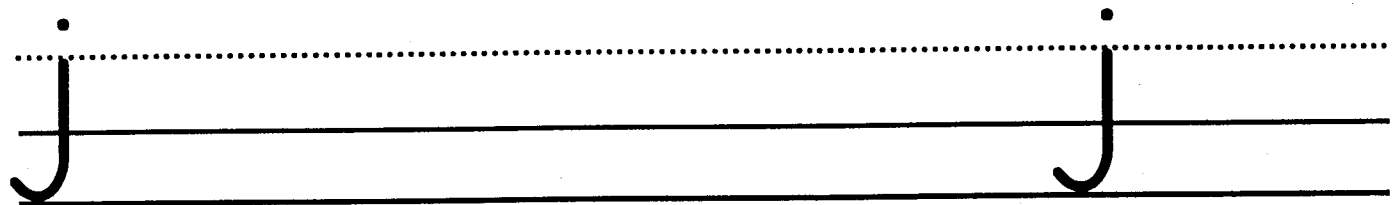
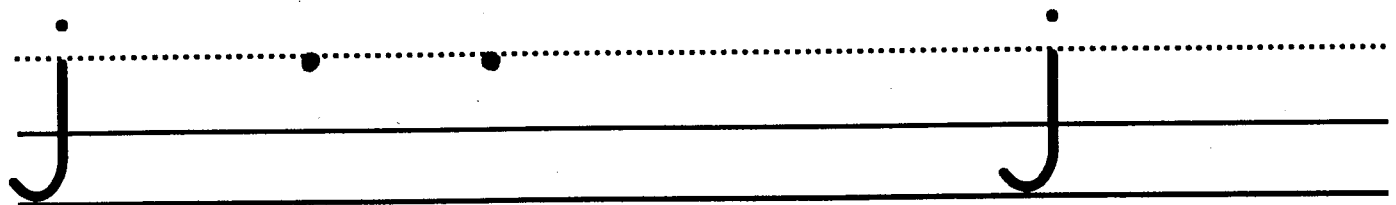
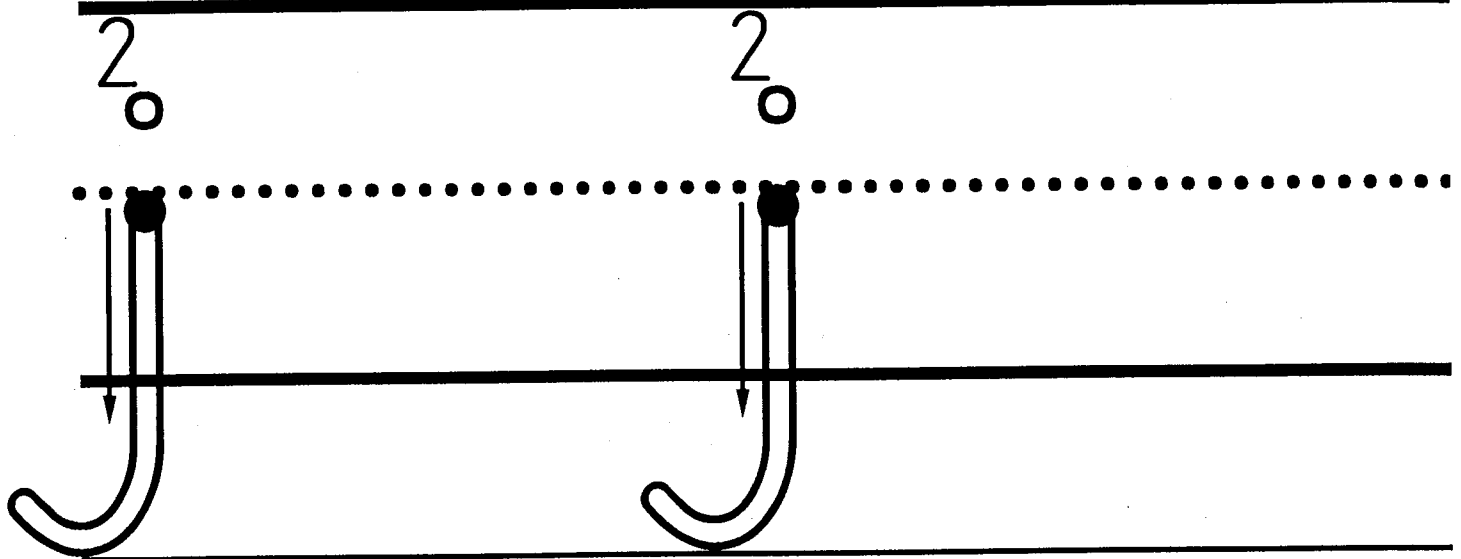

A cat can jog.

A _ _ t _ _ n

Spalding Lower-case Manuscript Letters

Rules: All letters sit on a base line. Letters are either tall or short.

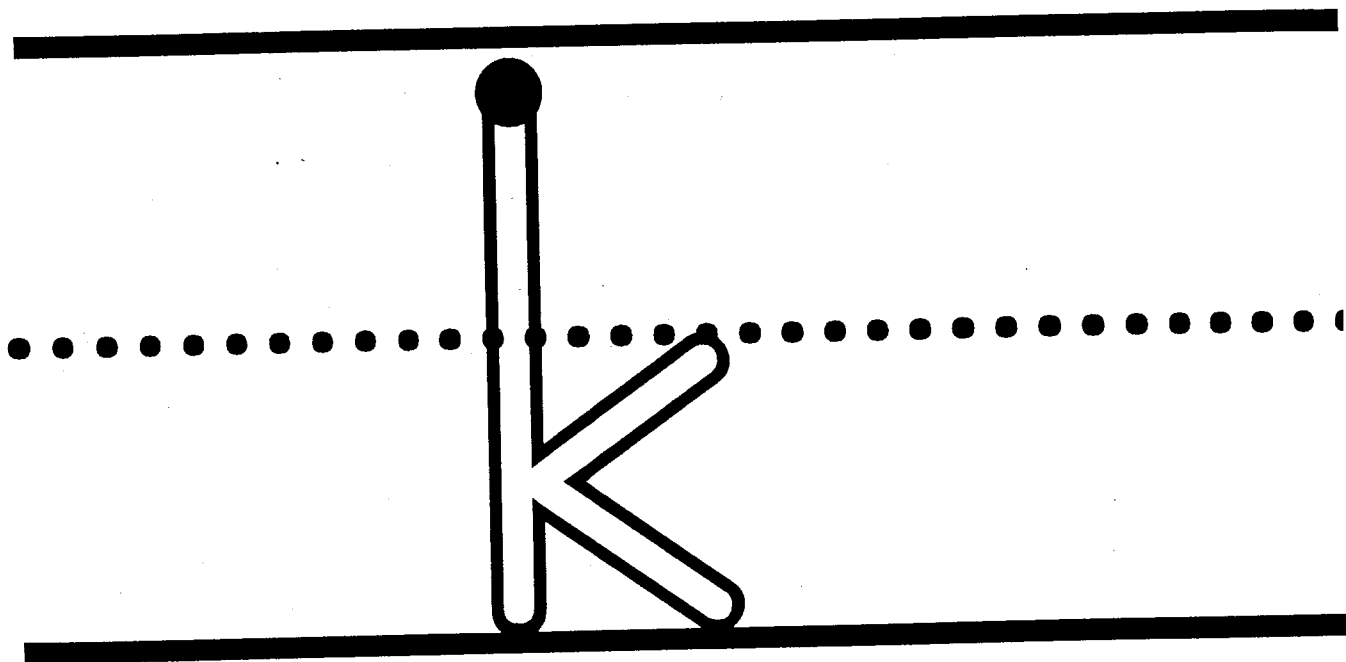

The first part is tall and starts at the top. The second part is separate. It is short and starts at the middle, going in and out the same distance.

Spalding Lower-case Manuscript Letters

*Rules: All letters sit on a base line. Letters are either tall or short.
The first part is tall and starts at the top. The second part is separate. It is short and starts at the middle, going in and out the same distance.*

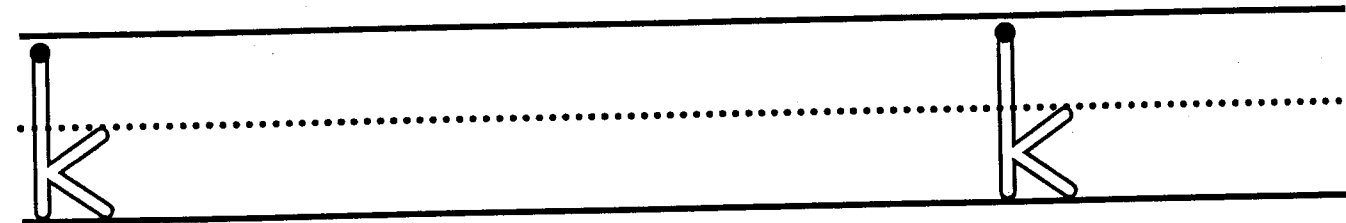
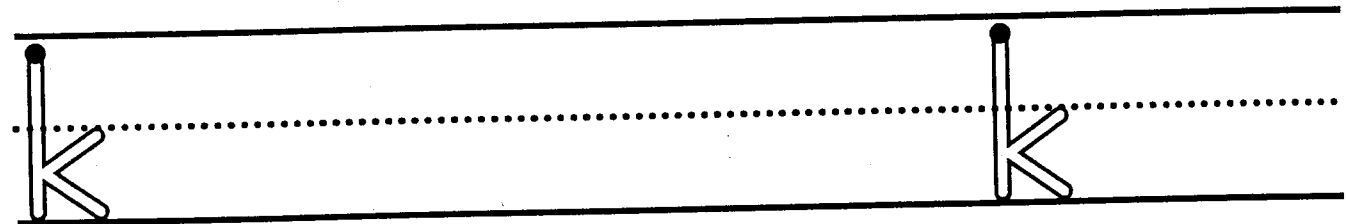
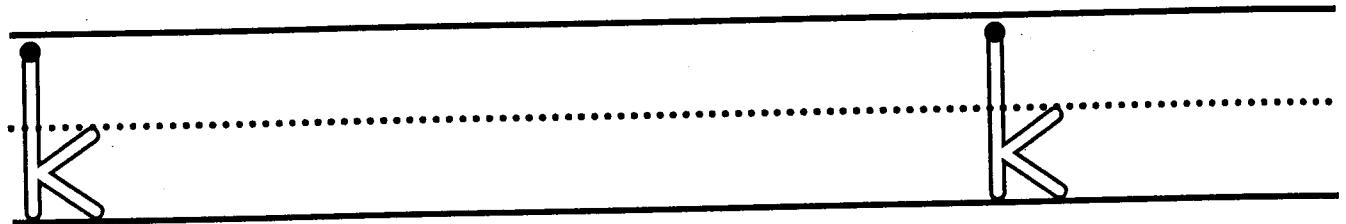
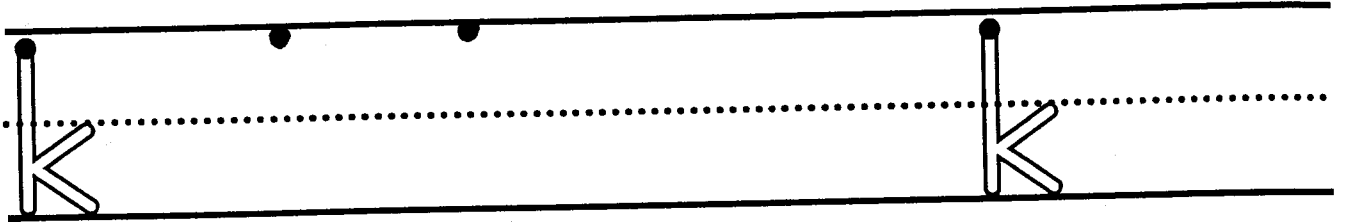

The first part is tall and starts at the top. The second part is separate. It is short and starts at the middle, going in and out the same distance.

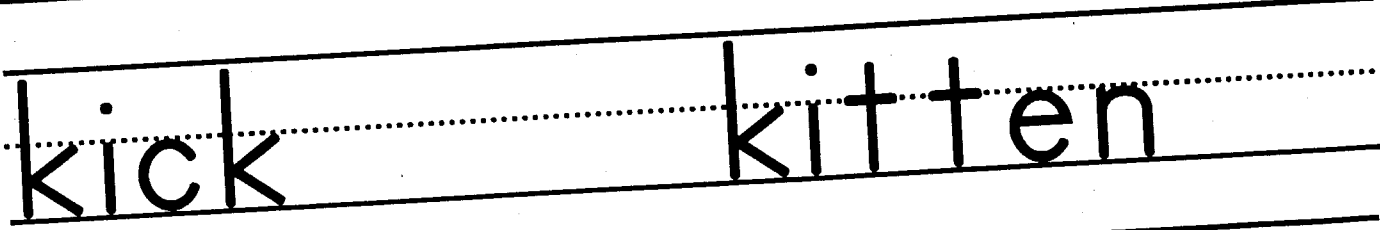
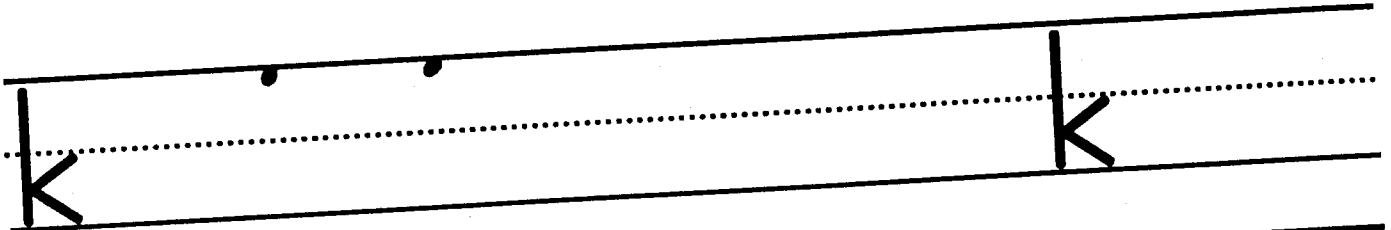
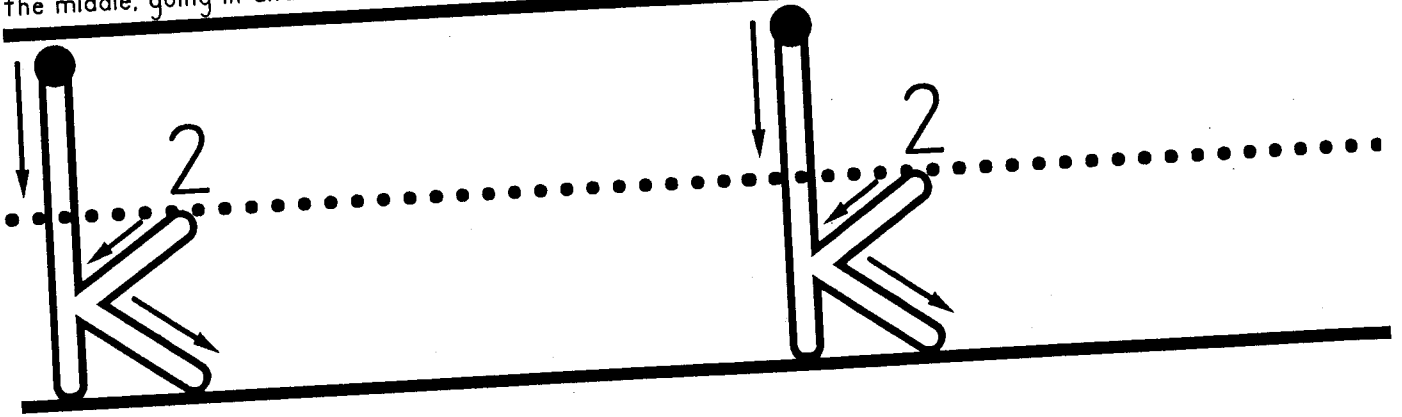

Spalding Lower-case Manuscript Letters

Rules: All letters sit on a base line. Letters are either tall or short.

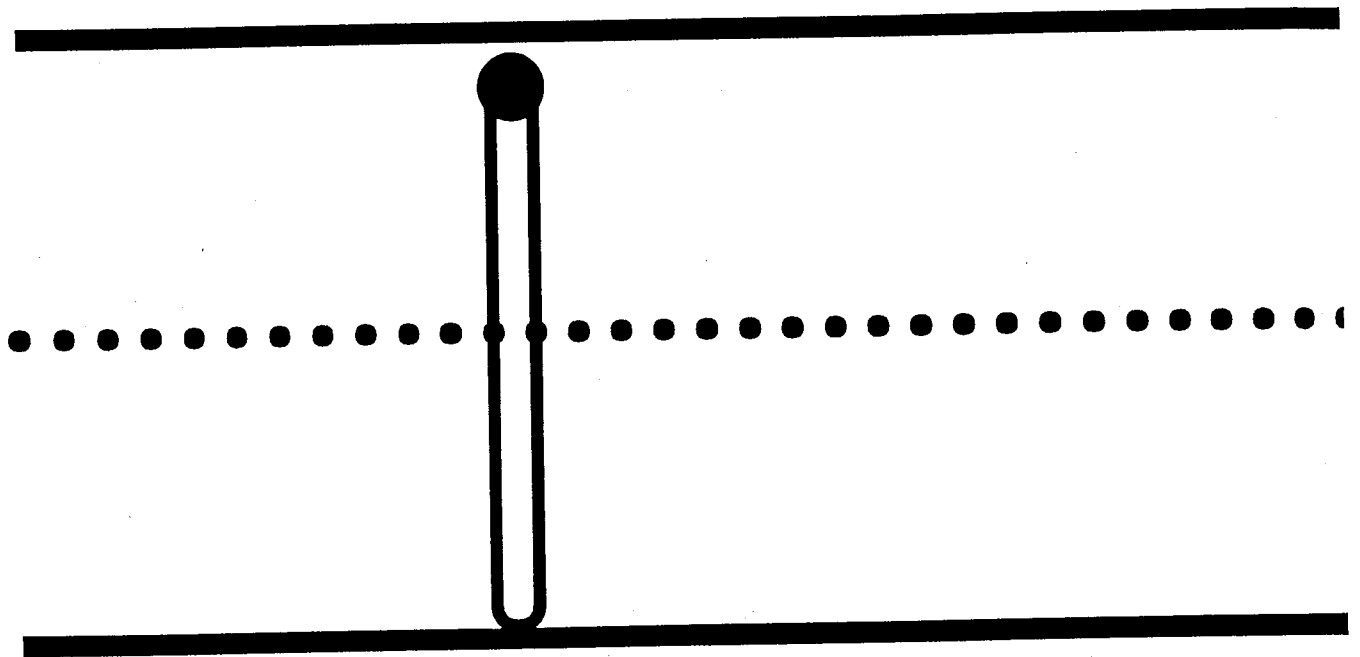

It is a tall line which starts at the top and sits on the base line.

Spalding Lower-case Manuscript Letters

Rules: All letters sit on a base line. Letters are either tall or short.

This is a tall line which starts at the top and sits on the base line.

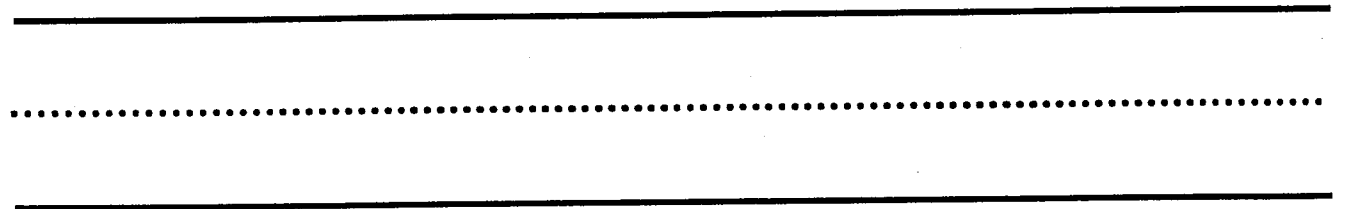
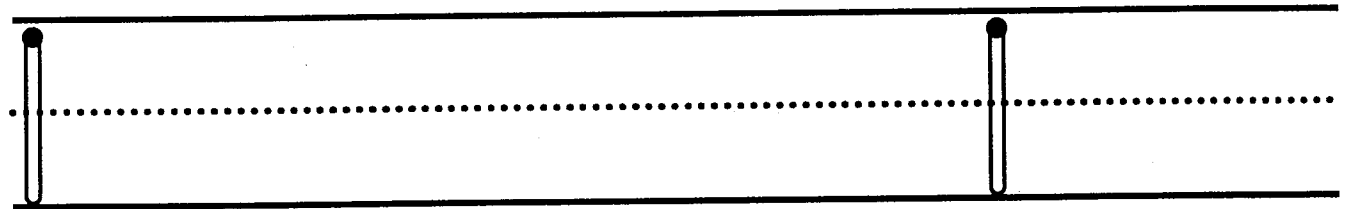
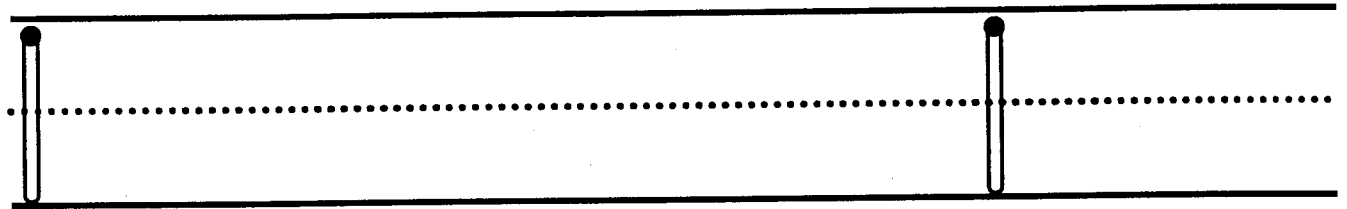
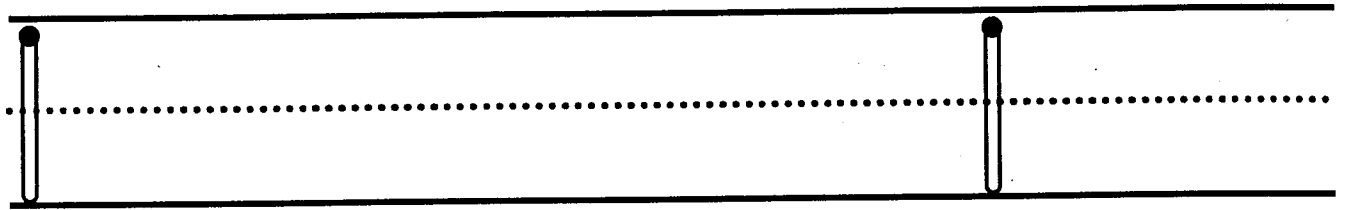
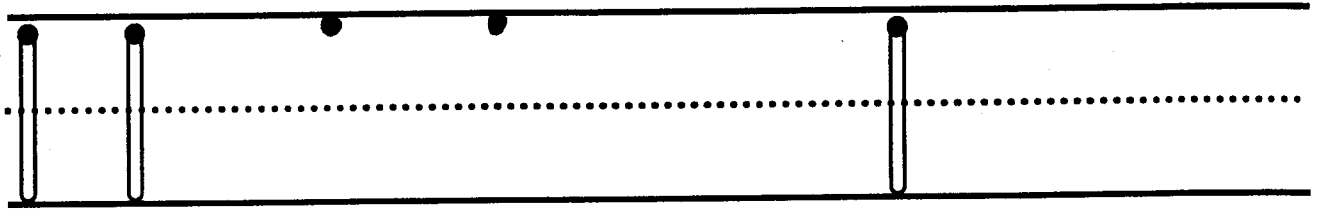

It is a tall line which starts at the top and sits on the base line.

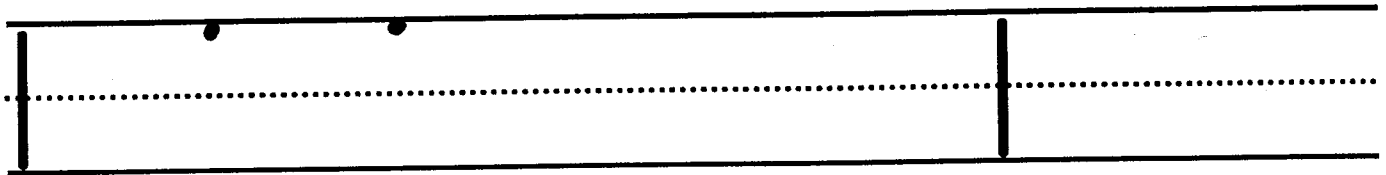
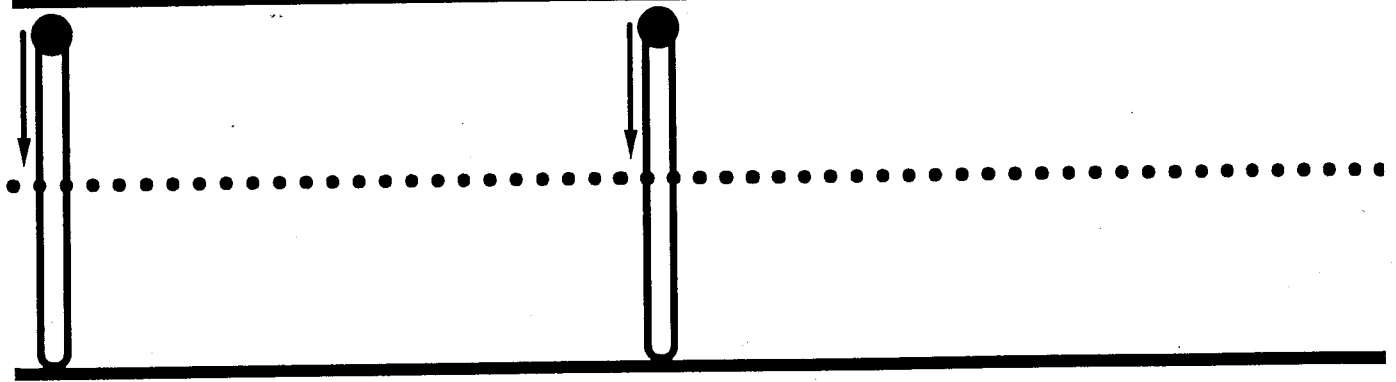

lick lose

Spalding Lower-case Manuscript Letters

Rules: All letters sit on a base line. Letters are either tall or short.

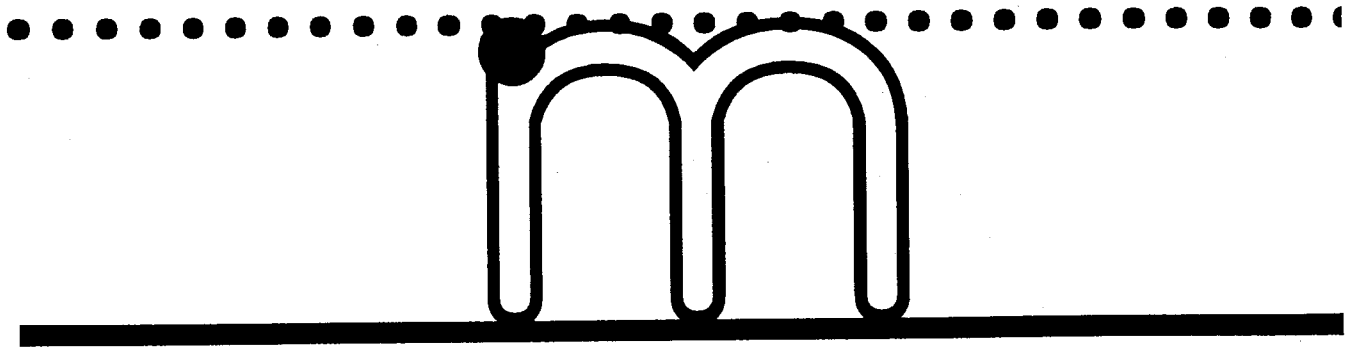
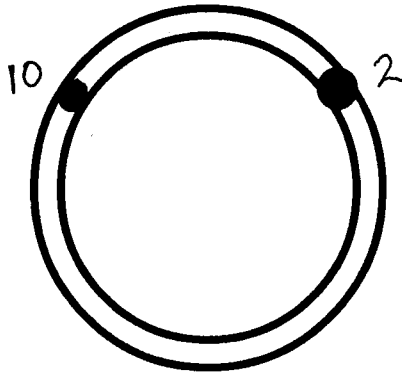

It is a short letter that begins with a line. It starts at the middle and is drawn straight down to the base line. Retrace to the top and round it on the clock from 10 to 2, continue by making a straight line to the base line, retrace to the top of the line, round again from 10 to 2 and finish with a straight line which ends at the base line.

Spalding Lower-case Manuscript Letters

Rules: All letters sit on a base line. Letters are either tall or short.

This is a short letter that begins with a line. It starts at the middle and is drawn straight down to the base line. Retrace to the top and round it on the clock from 10 to 2, continue by making a straight line to the base line, retrace to the top of the line, round again from 10 to 2, and finish with a straight line which ends at the base line.

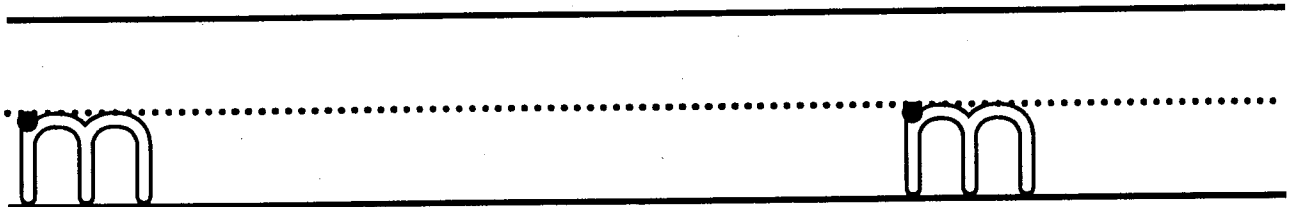
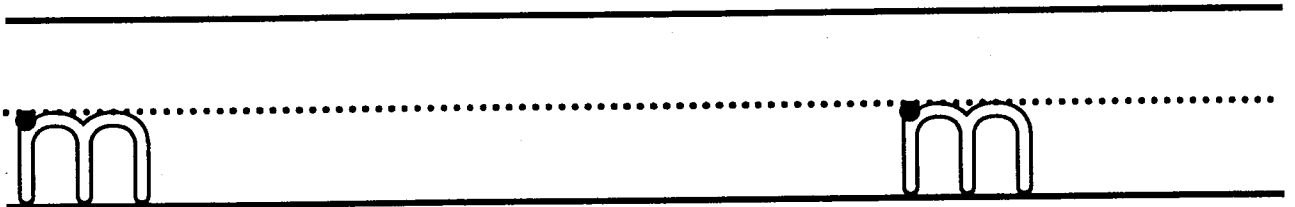
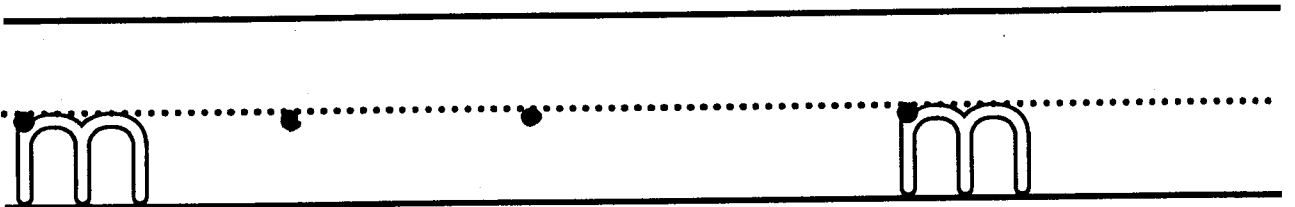
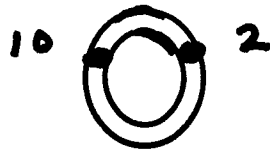

m is a short letter that begins with a line. It starts at the middle and is drawn straight down to the base line. Retrace to the top and round it on the clock from 10 to 2. continue by making a straight line to the base line, retrace to the top of the line, round again from 10 to 2, and finish with a straight line which ends at the base line.

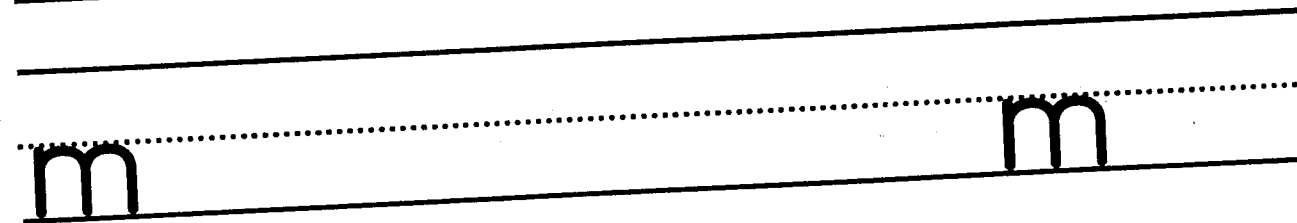
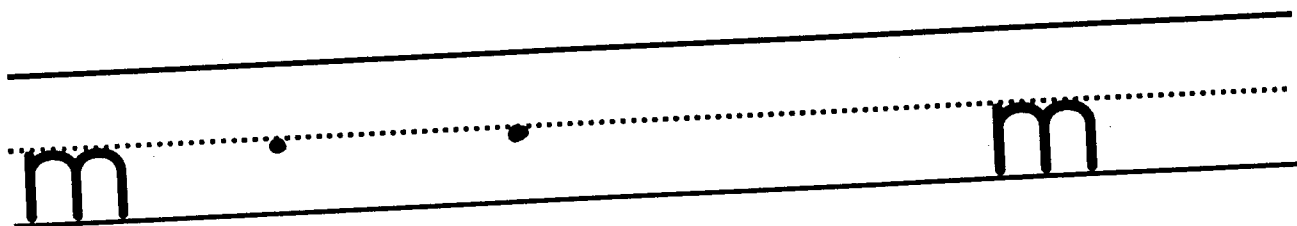
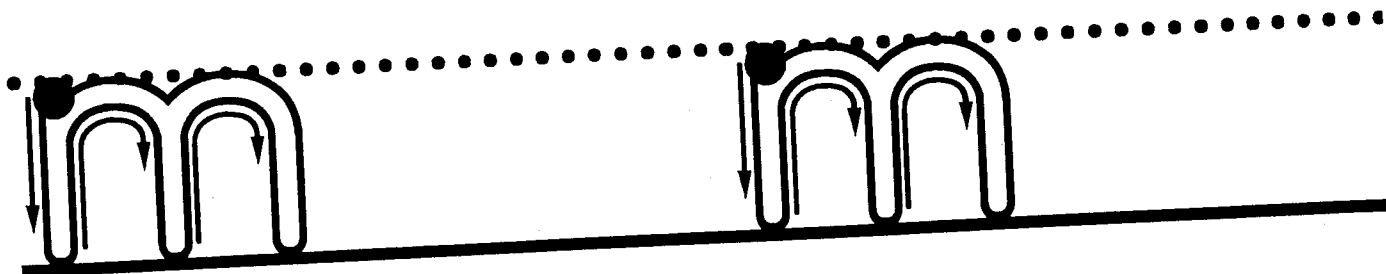

I see a man.

Spalding Lower-case Manuscript Letters

Rules: All letters sit on a base line. Letters are either tall or short.

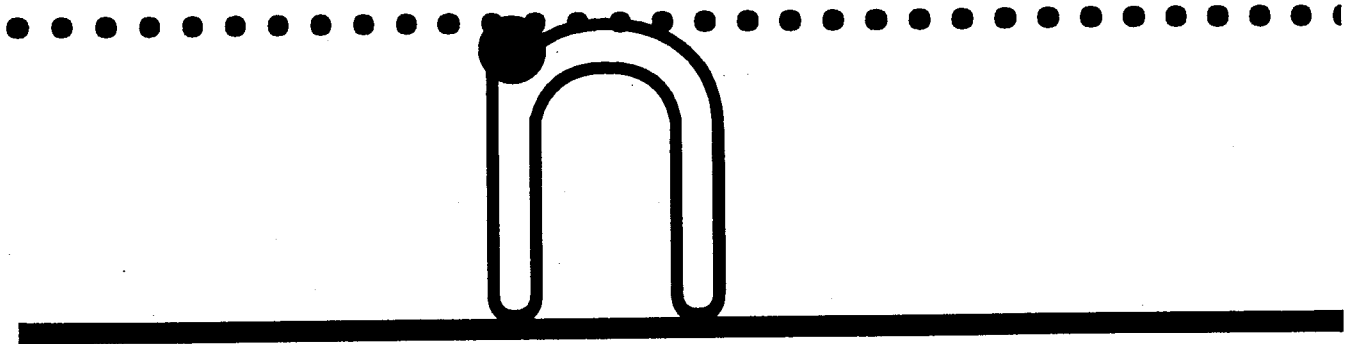
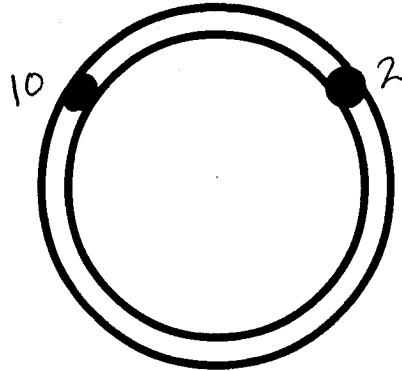

It is a short letter that begins with a line. It starts at the middle and is drawn straight down to the base line. Retrace to the top and round it on the clock from 10 to 2. continue by making a straight line to the base line.

Spalding Lower-case Manuscript Letters

Rules: All letters sit on a base line. Letters are either tall or short.
This is a short letter that begins with a line. It starts at the middle and is drawn straight down to the base line. Retrace to the top and round it on the clock from 10 to 2, continue by making a straight line to the base line.

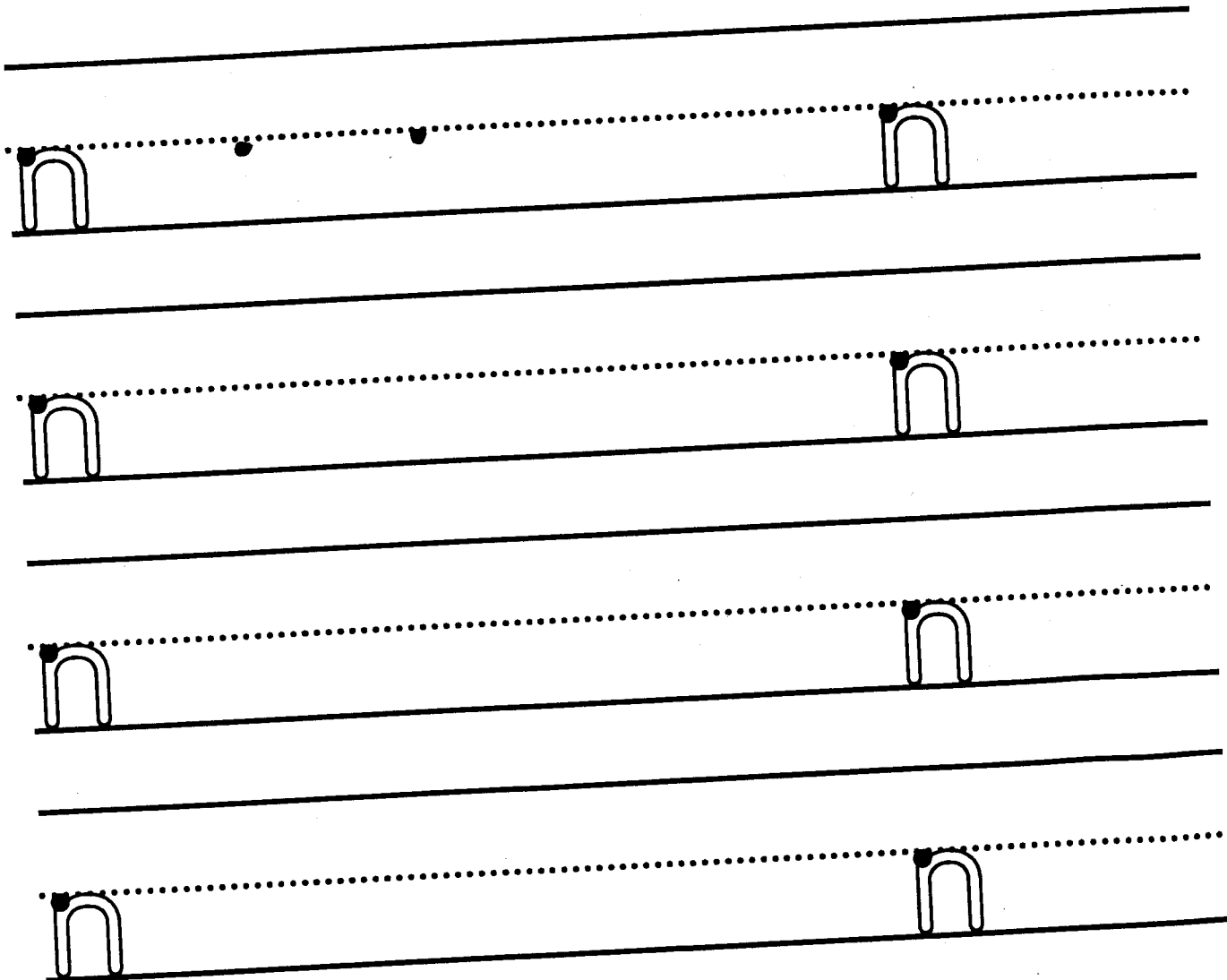
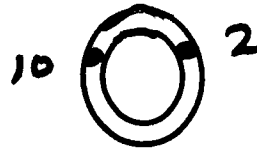

It is a short letter that begins with a line. It starts at the middle and is drawn straight down to the base line. Retrace to the top and round it on the clock from 10 to 2. Continue by making a straight line to the base line.

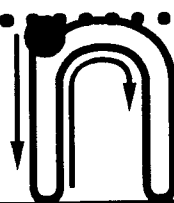
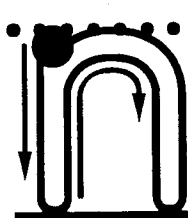

n

.

.

n

n

n

I see a man.

Spalding Lower-case Manuscript Letters

Rules: All letters sit on a base line. Letters are either tall or short.

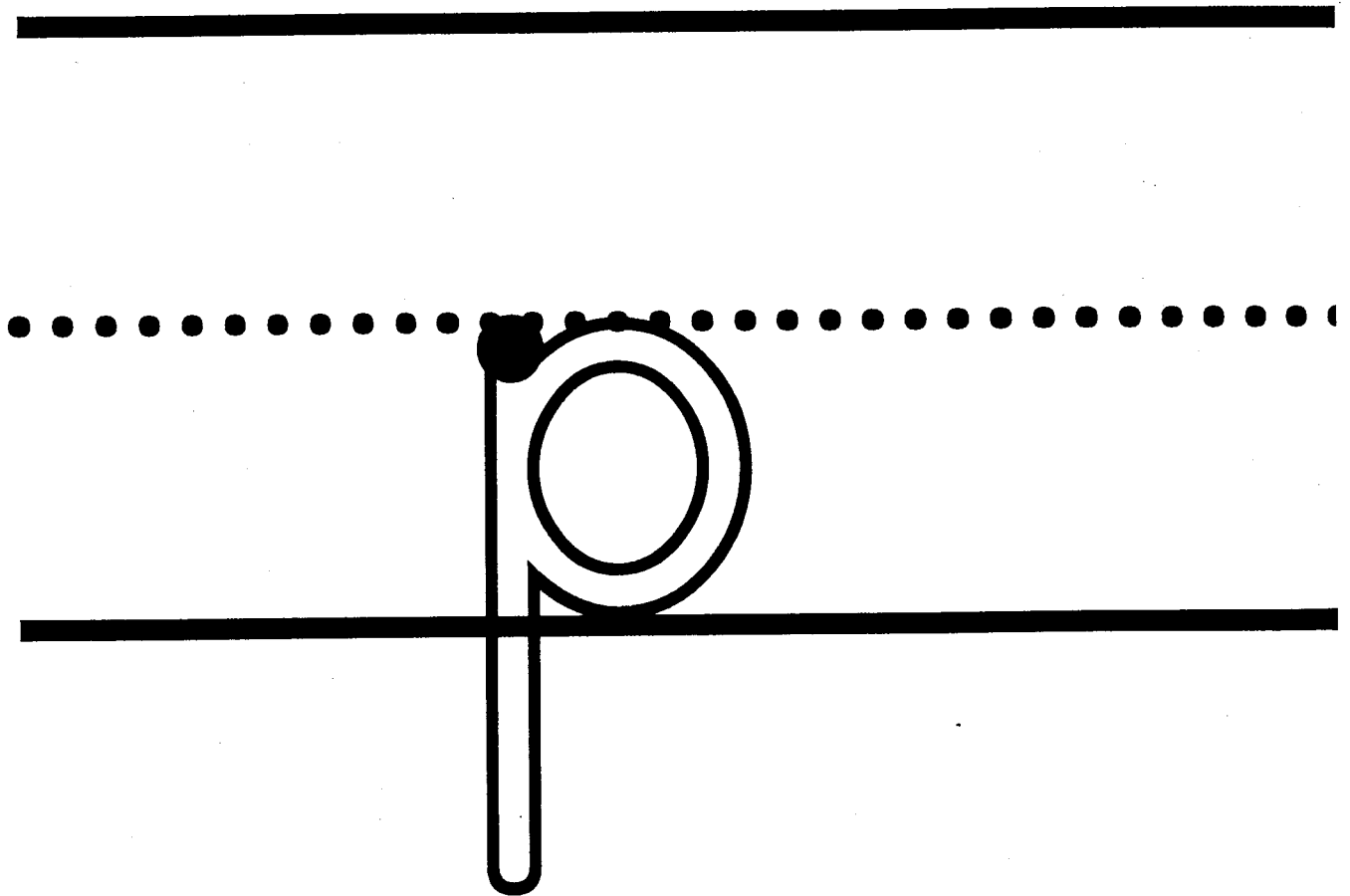
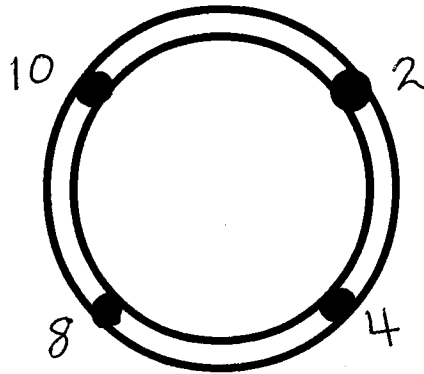

The line starts at the top and goes below the base line. Retrace on this line to the top and round the second part from 10 to 8 on the clock.

Spalding Lower-case Manuscript Letters

Rules: All letters sit on a base line. Letters are either tall or short.
The line starts at the top and goes below the base line. Retrace on this line to the top and round the second part from 10 to 8 on the clock.

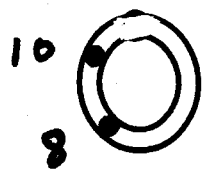

The line starts at the top and goes below the base line. Retrace on this line to the top and round the second part from 10 to 8 on the clock.

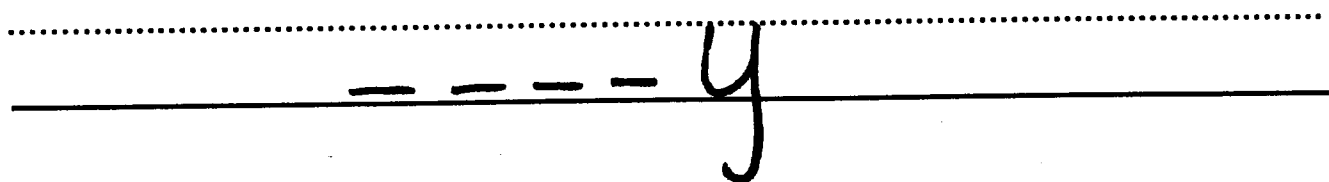
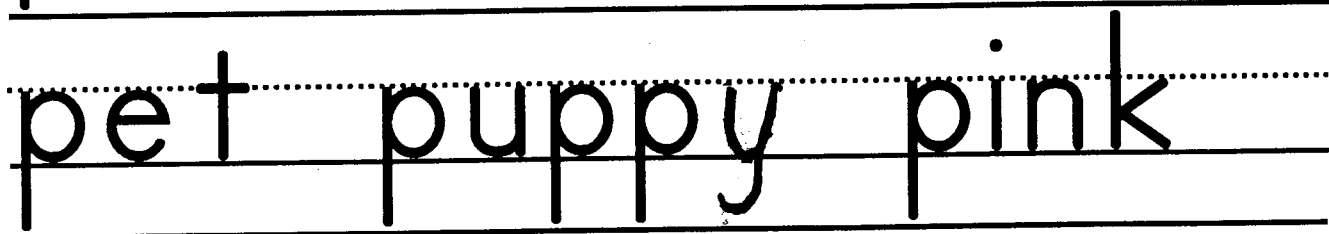
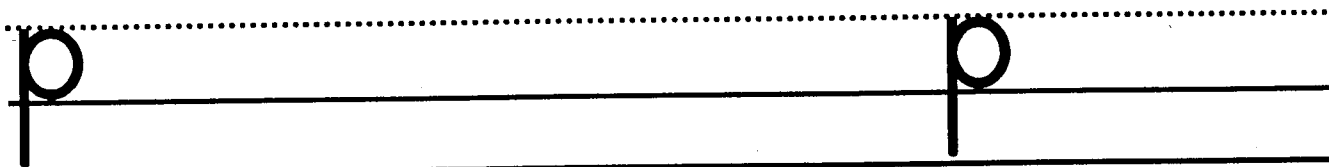
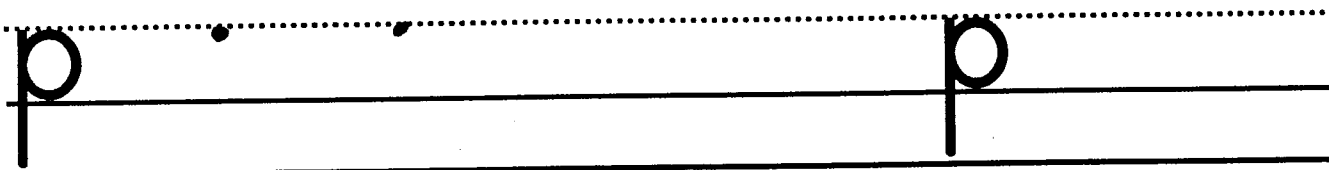
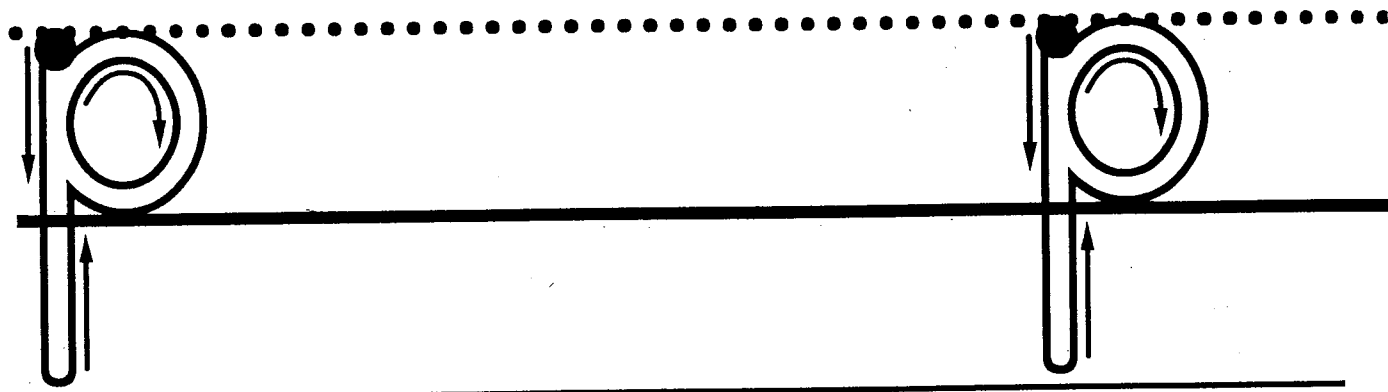

Spalding Lower-case Manuscript Letters

Rules: All letters sit on a base line. Letters are either tall or short.

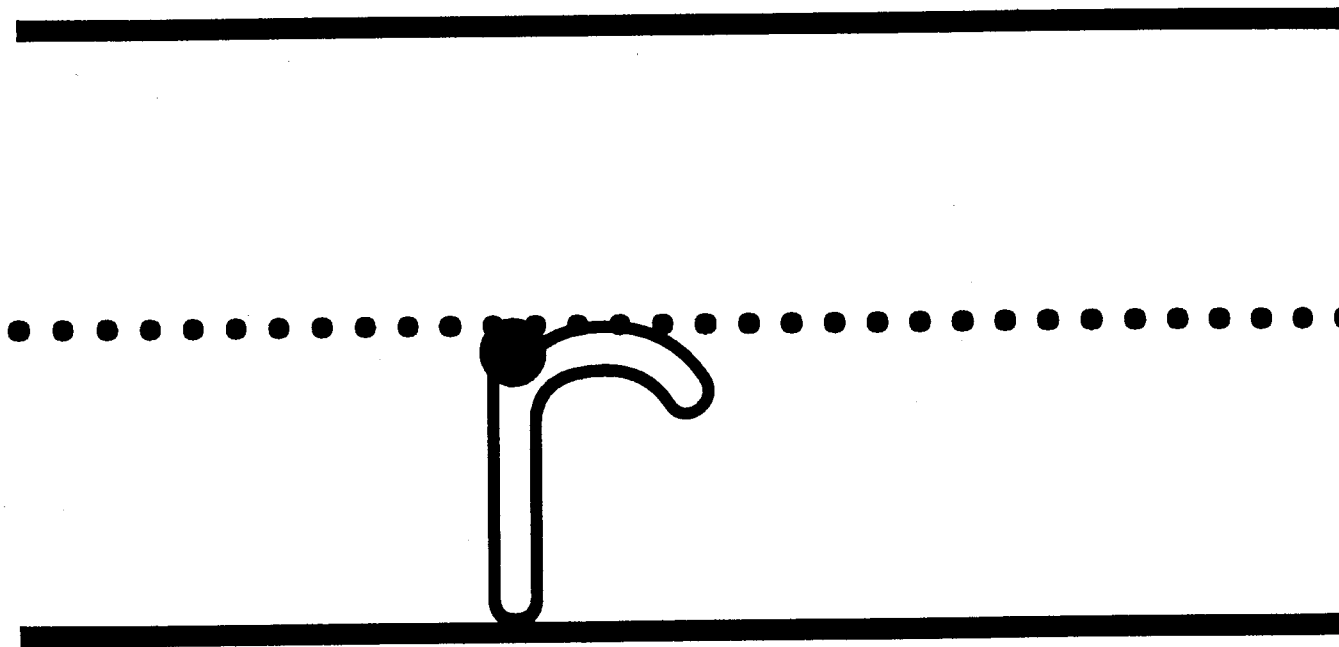
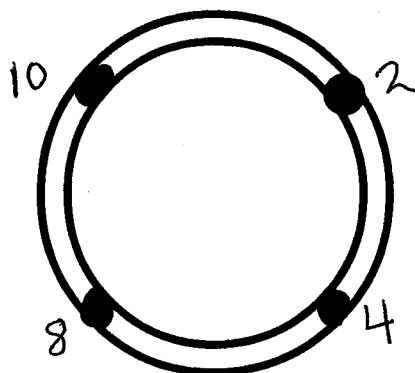

This short letter starts in the middle. Make the short line go to the base line. Retrace to the top and round it from 10 to 2 on the clock.

Spalding Lower-case Manuscript Letters

Rules: All letters sit on a base line. Letters are either tall or short.
This short letter starts in the middle. Make the short line go to the base line.
Retrace to the top and round it from 10 to 2 on the clock.

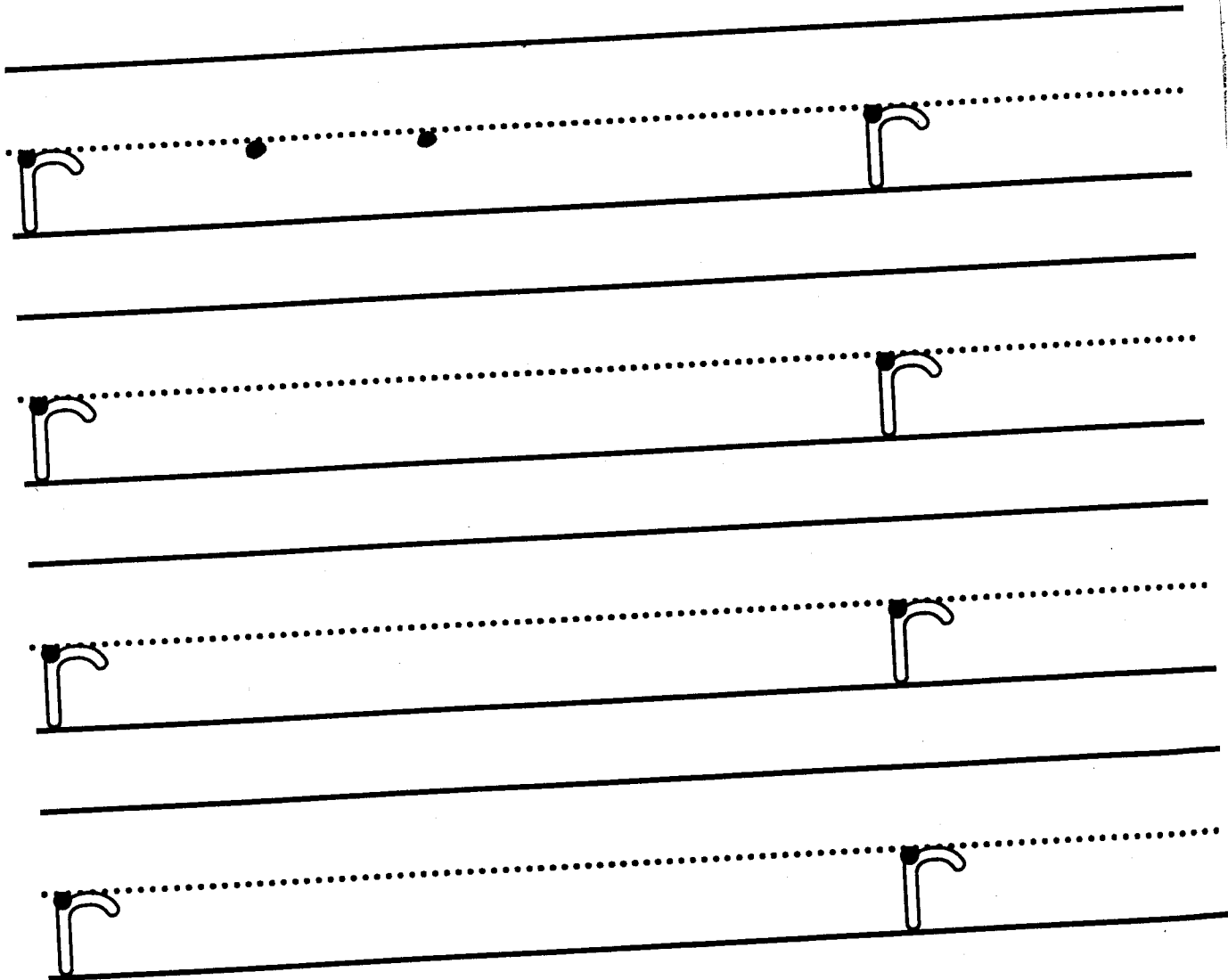

This short letter starts in the middle. Make the short line go to the base line. Retrace to the top and round it from 10 to 2 on the clock

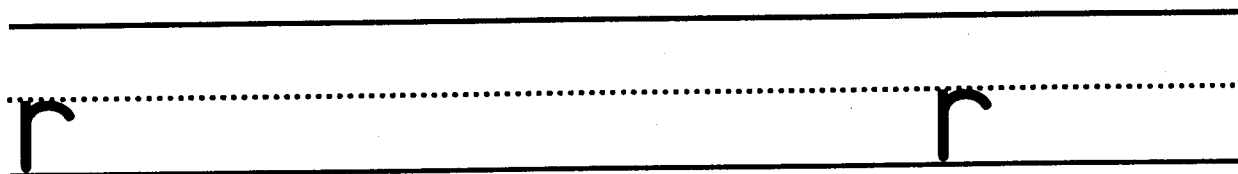
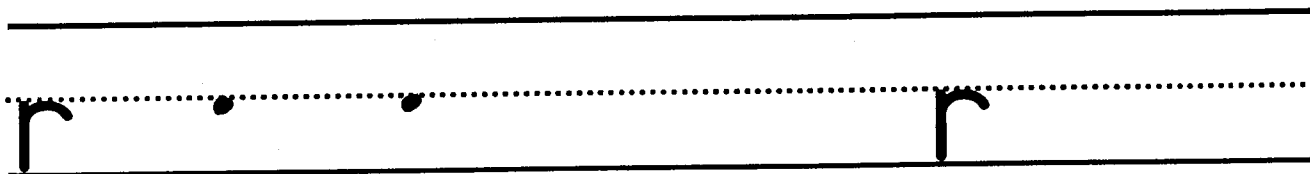
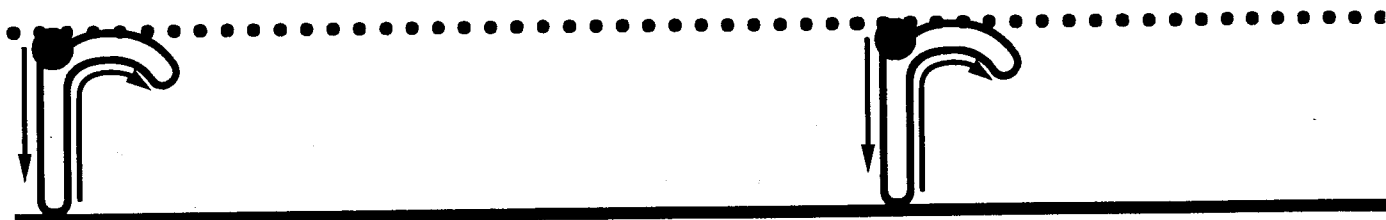

I see a red rat.

— — t.

Spalding Lower-case Manuscript Letters

Rules: All letters sit on a base line. Letters are either tall or short.

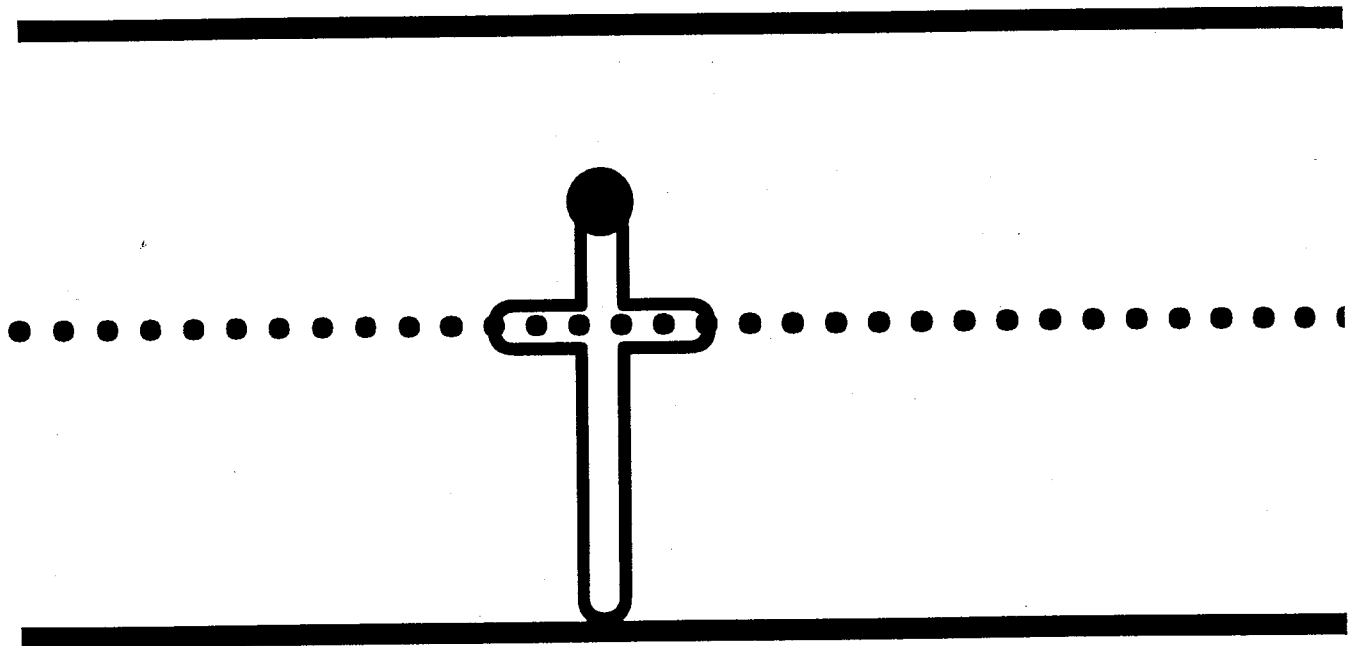

This is a tall letter. It begins at the top. The cross is small and drawn just above the center in the direction in which we write.

Spalding Lower-case Manuscript Letters

Rules: All letters sit on a base line. Letters are either tall or short.

This is a tall letter. It begins at the top. The cross is small and drawn just above the center in the direction in which we write.

